

---

# Basic Geometrical Optics

---

*Leno S. Pedrotti*

*CORD*

*Waco, Texas*

Optics is the cornerstone of photonics systems and applications. In this module, you will learn about one of the two main divisions of basic optics—*geometrical (ray) optics*. In the module to follow, you will learn about the other—*physical (wave) optics*. *Geometrical optics* will help you understand the basics of light reflection and refraction and the use of simple optical elements such as mirrors, prisms, lenses, and fibers. *Physical optics* will help you understand the phenomena of light wave interference, diffraction, and polarization; the use of thin film coatings on mirrors to enhance or suppress reflection; and the operation of such devices as gratings and quarter-wave plates.

## Prerequisites

Before you work through this module, you should have completed Module 1-1, *Nature and Properties of Light*. In addition, you should be able to manipulate and use algebraic formulas, deal with units, understand the geometry of circles and triangles, and use the basic trigonometric functions (sin, cos, tan) as they apply to the relationships of sides and angles in right triangles.

## Objectives

When you finish this module you will be able to:

- Distinguish between light rays and light waves.
- State the *law of reflection* and show with appropriate drawings how it applies to light rays at plane and spherical surfaces.
- State *Snell's law of refraction* and show with appropriate drawings how it applies to light rays at plane and spherical surfaces.
- Define *index of refraction* and give typical values for glass, water, and air.
- Calculate the *critical angle* of incidence for the interface between two optical media and describe the process of *total internal reflection*.
- Describe how total internal reflection can be used to redirect light in prisms and trap light in fibers.
- Describe *dispersion* of light and show how a prism disperses white light.
- Calculate the *minimum angle of deviation* for a prism and show how this angle can be used to determine the refractive index of a prism material.
- Describe what is meant by *Gaussian* or *paraxial* optics.
- Describe the relationship between *collimated light* and the *focal points* of convex and concave *mirrors*.
- Use *ray-tracing techniques* to locate the images formed by plane and spherical mirrors.
- Use the *mirror equations* to determine location, size, orientation, and nature of images formed with spherical mirrors.
- Distinguish between a *thin lens* and a *thick lens*.
- Describe the shapes of three typical *converging (positive)* thin lenses and three typical *diverging (negative)* thin lenses.
- Describe the *f-number* and *numerical aperture* for a lens and explain how they control image brightness.
- Use *ray-tracing techniques* to locate images formed by *thin lenses*.
- Describe the relationship between *collimated light* and the *focal points* of a *thin lens*.
- Use the *lensmaker's equation* to determine the focal length of a thin lens.
- Use the *thin-lens equations* to determine location, size, orientation, and nature of the images formed by simple lenses.

**Scenario—Using Geometrical Optics in the Workplace**

*Manuel Martinez is a photonics technician hired recently to work for a large optical company that manufactures optical components such as mirrors, lenses, prisms, beam splitters, fibers, and Brewster windows—all to customer specifications. While in school Manuel studied light imaging with mirrors and lenses, ray tracing, and calculations with simple formulas. After two months on the job he has discovered that he uses those same ideas day in and day out. To be sure, things are much more “high tech” in his company, for now Manuel has access to powerful computers and computer programs that trace rays through complicated optical systems, often containing elements with nonspherical surfaces, something Manuel never had a chance to do at school. He enjoys the challenge of using state-of-the-art lab equipment he’s never seen before, including autocollimators, spectroreflectometers, and surface profilers. All in all, he’s really satisfied because all of the optics he had in his “Geo” course back at school really prepared him well for his laboratory work here. This month Manuel is learning how to “grind and polish optical surfaces to spec,” and how to apply the principles of geometrical optics to determine when the surfaces are “near tolerance.” Manuel finds his work fascinating and can hardly wait to get to work each morning. “Geo” was never so much fun.*

**Opening Demonstrations**

*Note: The hands-on exercises that follow are to be used as short introductory laboratory demonstrations. They are intended to provide you with a glimpse of some of the phenomena covered in this module and to stimulate your interest in the study of optics and photonics.*

**1. Comparing Ordinary Light with Laser Light.** In an appropriately darkened room, and with plenty of “chalked-up” erasers, examine the dramatic difference between ordinary “flashlight” light and laser light. Use a focusable mini MAGLITE (MAG Instrument, Ontario, Canada, 909-947-1006) and a well-collimated, ordinary low power (5.0 mW or less) diode laser pointer (Edmund Scientific Company, Barrington, New Jersey, 609-573-6250). Shine each light beam, in turn, from one side of the room to the other. Have participants “pat the erasers” together over the entire path of the light beams. The light beams outline themselves dramatically as they scatter their light energy off the settling chalk particles. Which beam remains well defined along its path? Which beam more closely describes a “ray of light”?

**2. Bending Light Rays in a Fish Tank.** Fill an ordinary rectangular five-gallon acrylic fish tank half full of water. Use the diode laser pointer to trace a “light ray” through the water in the fish tank.

**a.** Attach the laser—generally cylindrical in shape—to a stand, making sure that it can be directed easily in different directions. From above the tank, direct a beam onto the top of the water at an angle of incidence near  $50^\circ$ . (A plane mirror placed under the tank will reflect more light back into the water.) See sketch D-1 below. Use milk or a food coloring (very sparingly—a drop at a time) to illuminate the beam. Experimenting beforehand—with a smaller container—to determine the right amount of coloring will pay big dividends. With the ray visible in the tank, observe the bending of the light beam as it moves from air into water, the phenomenon of *refraction*.

**b.** Next, direct the diode laser beam through one wall of the tank, up toward the water surface. See sketch D-2. Experiment with the laser beam direction until no light emerges at the water-air surface and the beam is seen to be totally reflected back into the water. The incident angle at the water-air interface is now larger than the critical angle. This phenomenon of total internal reflection is used to trap light in fibers.

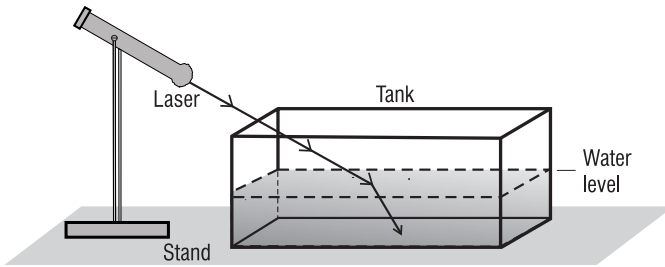

(D-1)

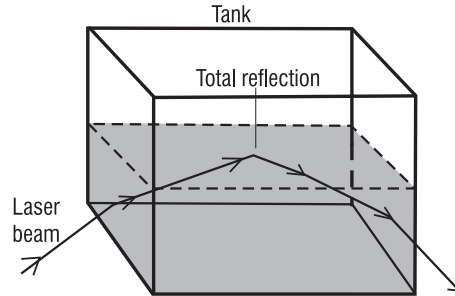

(D-2)

**3. Focusing Parallel Light Rays with a Thin Lens.** Set up a positive thin lens, several inches in diameter and of focal length around 3 inches, on an optical bench. Arrange two diode laser pointers, on stands, so that they send parallel beams onto the front surface of the lens, near its outer edge. See sketch D-3. Lower the room lights and use chalk dust as in Demonstration 1 to illuminate the beams on the imaging side of the lens. The distance from the lens to the point where the beams cross is the *focal length* of the lens. Repeat with a negative lens of the same diameter and focal length, sketch D-4. What do the beams do? Where is the focal point?

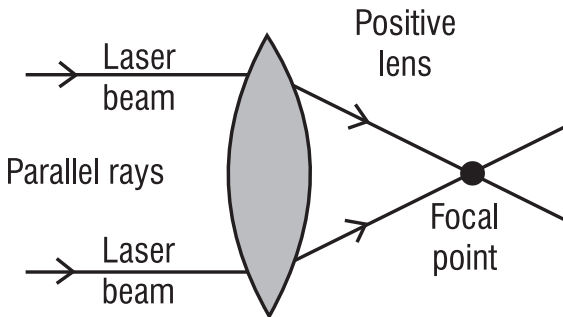

(D-3)

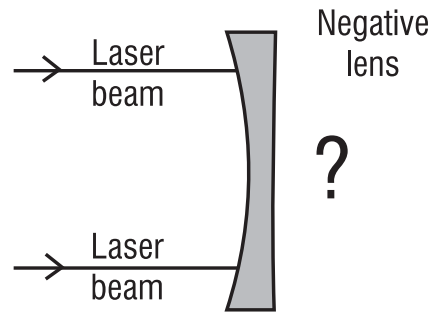

(D-4)

# Basic Concepts

## I. THE LAWS OF REFLECTION AND REFRACTION

We begin our study of *basic geometrical optics* by examining how light reflects and refracts at smooth, plane interfaces. Figure 3-1a shows ordinary reflection of light at a plane surface, and Figure 3-1b shows refraction of light at two successive plane surfaces. In each instance, light is pictured simply in terms of straight lines, which we refer to as *light rays*.

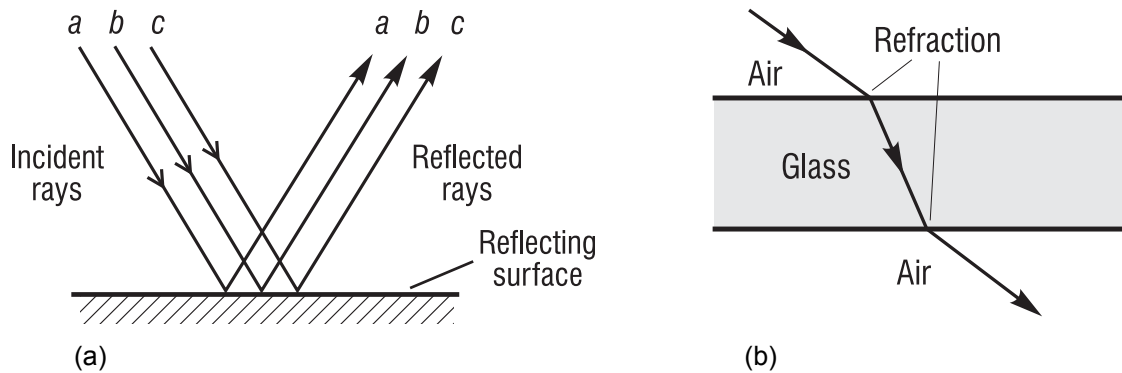

**Figure 3-1** Light rays undergoing reflection and refraction at plane surfaces

After a study of how light reflects and refracts at plane surfaces, we extend our analysis to smooth, curved surfaces, thereby setting the stage for light interaction with mirrors and lenses—the basic elements in many optical systems.

In this module, the analysis of how light interacts with plane and curved surfaces is carried out with *light rays*. A light ray is nothing more than an imaginary line directed along the path that the light follows. It is helpful to think of a light ray as a narrow pencil of light, very much like a narrow, well-defined laser beam. For example, earlier in this module, when you observed the passage of a laser beam in a fish tank and visually traced the path of the beam from reflection to reflection inside the tank, you were, in effect, looking at a “light ray” representation of light in the tank.

### A. Light rays and light waves

Before we look more closely at the use of *light rays* in geometrical optics, we need to say a brief word about *light waves* and the geometrical connection between light rays and light waves. For most of us, wave motion is easily visualized in terms of water waves—such as those created on a quiet pond by a bobbing cork. See Figure 3-2a. The successive high points (crests) and low points (troughs) occur as a train of circular waves moving radially outward from the bobbing cork. Each of the circular waves represents a *wave front*. A wave front is defined here as a locus of points that connect identical wave displacements—that is, identical positions above or below the normal surface of the quiet pond.



(a) Waves from a bobbing cork

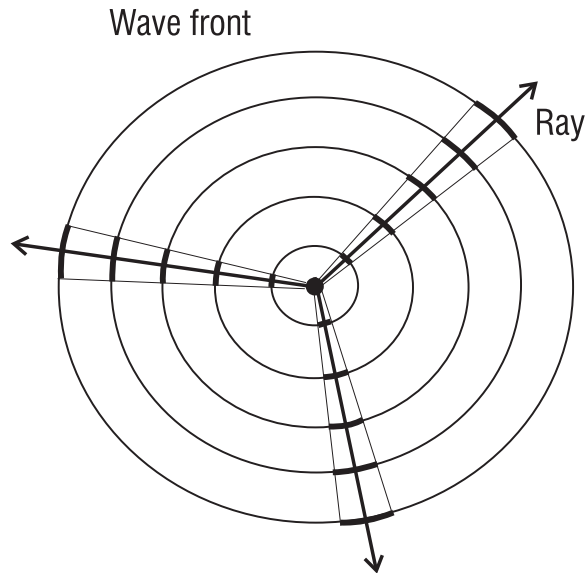

(b) Light rays and wave fronts

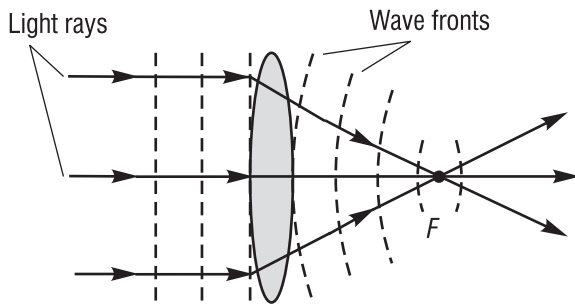

(c) Changing wave fronts and bending light rays

**Figure 3-2** *Waves and rays*

In Figure 3-2b, circular wave fronts are shown with radial lines drawn perpendicular to them along several directions. Each of the rays describes the motion of a *restricted part* of the wave front along a particular direction. Geometrically then, a *ray* is a line perpendicular to a series of successive *wave fronts* specifying the *direction of energy flow* in the wave.

Figure 3-2c shows plane wave fronts of light bent by a lens into circular (spherical in three dimensions) wave fronts that then converge onto a focal point  $F$ . The same diagram shows the *light rays* corresponding to these wave fronts, bent by the lens to pass through the same focal point  $F$ . Figure 3-2c shows clearly the connection between actual waves and the rays used to represent them. In the study of geometrical optics, we find it acceptable to represent the interaction of light waves with plane and spherical surfaces—with mirrors and lenses—in terms of *light rays*.

With the useful geometric construct of a light ray we can illustrate propagation, reflection, and refraction of light in clear, uncomplicated drawings. For example, in Figure 3-3a, the propagation of light from a “point source” is represented by equally spaced light rays emanating from the source. Each ray indicates the geometrical path along which the light moves as it leaves the source. Figure 3-3b shows the reflection of several light rays at a curved mirror surface, and Figure 3-3c shows the refraction of a single light ray passing through a prism.

## BASIC GEOMETRICAL OPTICS

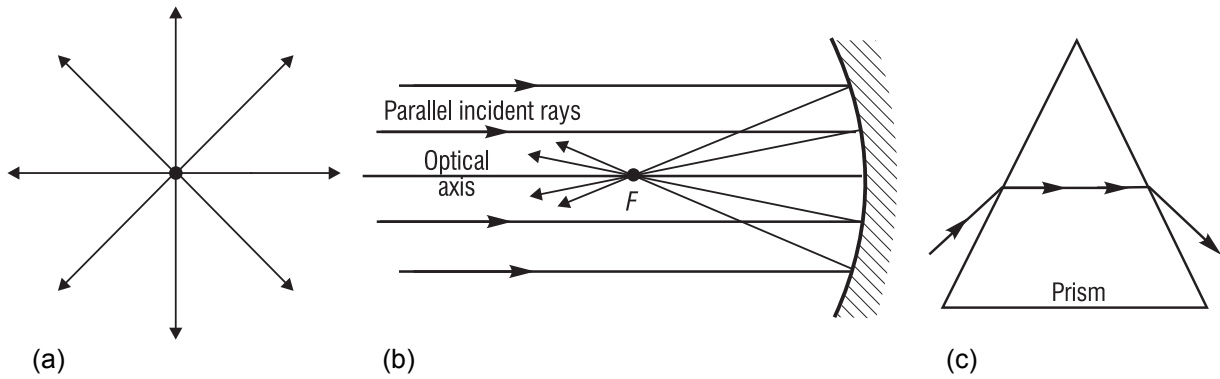

**Figure 3-3** Typical light rays in (a) propagation, (b) reflection, and (c) refraction

### B. Reflection of light from optical surfaces

When light is incident on an *interface* between two transparent optical media—such as between air and glass or between water and glass—four things can happen to the incident light.

- It can be partly or totally reflected at the interface.
- It can be scattered in random directions at the interface.
- It can be partly transmitted via refraction at the interface and enter the second medium.
- It can be partly absorbed in either medium.

In our introductory study of geometrical optics we shall consider only smooth surfaces that give rise to *specular* (regular, geometric) reflections (Figure 3-4a) and ignore ragged, uneven surfaces that give rise to *diffuse* (irregular) reflections (Figure 3-4b).

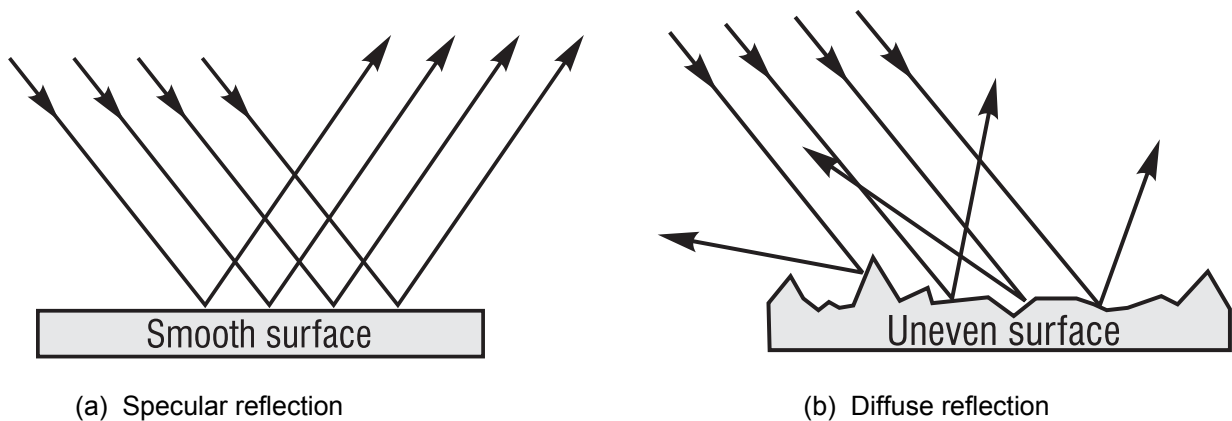

**Figure 3-4** Specular and diffuse reflection

In addition, we shall ignore absorption of light energy along the path of travel, even though absorption is an important consideration when percentage of light transmitted from source to receiver is a factor of concern in optical systems.

**1. The law of reflection: plane surface.** When light reflects from a plane surface as shown in Figure 3-5, the angle that the reflected ray makes with the *normal* (line perpendicular to the surface) at the point of incidence is *always equal* to the angle the incident ray makes with the same normal. Note carefully that the incident ray, reflected ray, and normal always lie in the *same* plane.

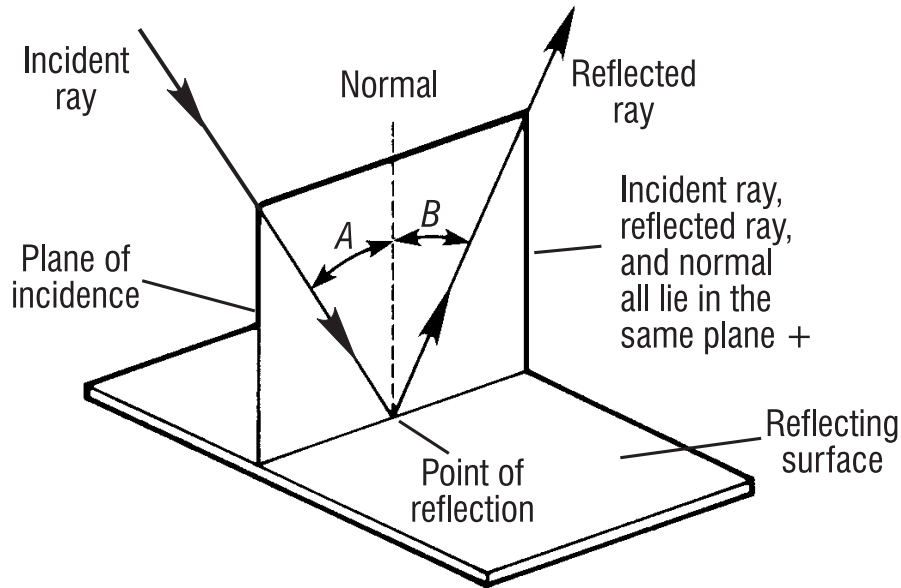

**Figure 3-5** Law of reflection: Angle  $B$  equals angle  $A$ .

The geometry of Figure 3-5 reminds us that reflection of light rays from a plane, smooth surface is like the geometry of pool shots “banked” along the wall of a billiard table.

With the *law of reflection* in mind, we can see that, for the specular reflection shown earlier in Figure 3-4a, each of the incident, parallel rays reflects off the surface at the same angle, thereby remaining parallel in reflection as a group. In Figure 3-4b, where the surface is made up of many *small*, randomly oriented plane surfaces, each ray reflects in a direction different from its neighbor, even though each ray does obey the *law of reflection* at its own small surface segment.

**2. Reflection from a curved surface.** With spherical mirrors, reflection of light occurs at a curved surface. The *law of reflection* holds, since at each point on the curved surface one can draw a *surface tangent* and erect a *normal* to a point  $P$  on the surface where the light is incident, as shown in Figure 3-6. One then applies the *law of reflection* at point  $P$  just as was illustrated in Figure 3-5, with the incident and reflected rays making the same angles ( $A$  and  $B$ ) with the normal to the surface at  $P$ . Note that successive surface tangents along the curved surface in Figure 3-6 are *ordered* (not random) sections of “plane mirrors” and serve—when smoothly connected—as a spherical surface mirror, capable of forming distinct images.



## BASIC GEOMETRICAL OPTICS

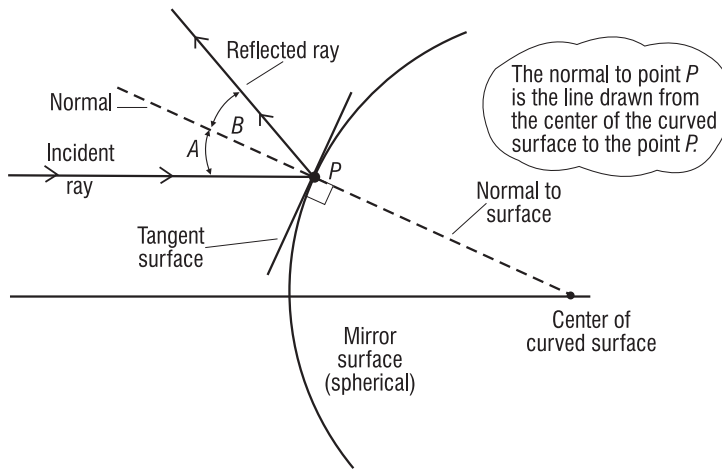
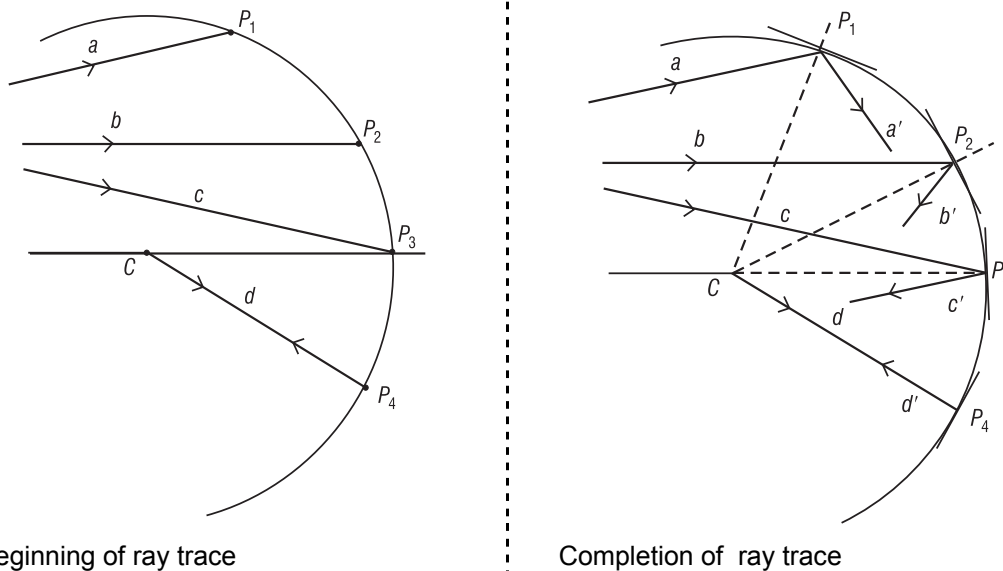

**Figure 3-6** Reflection at a curved surface: Angle  $B$  equals angle  $A$ .

Since point  $P$  can be moved anywhere along the curved surface and a normal drawn there, we can always find the direction of the reflected ray by applying the *law of reflection*. We shall apply this technique when studying the way mirrors reflect light to form images.

### Example 1

Using the *law of reflection*, complete the ray-trace diagram for the four rays ( $a, b, c, d$ ) incident on the curved surface shown at the left below, given the center of the curved surface is at point  $C$ .



**Solution:** Draw a normal (shown dashed) from point  $C$  to each of the points  $P_1, P_2, P_3,$  and  $P_4$ , as shown above in the drawing at the right. At each point, draw the appropriate reflected ray ( $a', b', c', d'$ ) so that it makes an angle with its normal equal to the angle made by the incident ray ( $a, b, c, d$ ) at that point. Note that ray  $d$  reflects *back along itself* since it is incident along the line of the normal from  $C$  to point  $P_4$ .

### C. Refraction of light from optical interfaces

When light is incident at an *interface*—the geometrical plane that separates one optical medium from another—it will be partly reflected and partly transmitted. Figure 3-7 shows a three-dimensional view of light incident on a partially reflecting surface (interface), being reflected there (according to the *law of reflection*) and refracted into the second medium. The bending of light rays at an interface between two optical media is called *refraction*. Before we examine in detail the process of refraction, we need to describe optical media in terms of an *index of refraction*.

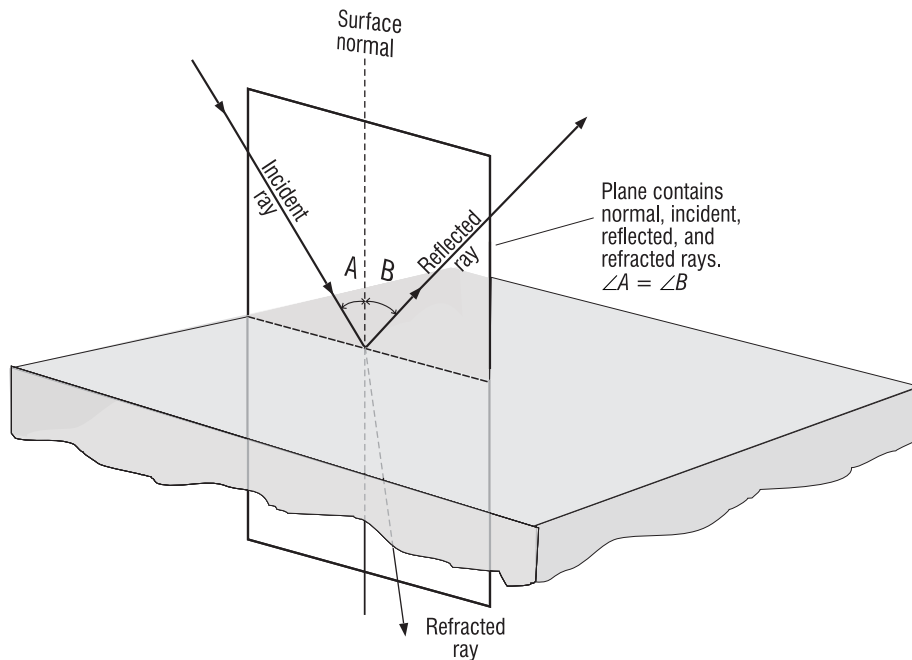

**Figure 3-7** Reflection and refraction at an interface

**1. Index of refraction.** The two transparent optical media that form an interface are distinguished from one another by a constant called the *index of refraction*, generally labeled with the symbol  $n$ . The index of refraction for any transparent optical medium is defined as the ratio of the speed of light in a vacuum to the speed of light in the medium, as given in Equation 3-1.

$$n = \frac{c}{v} \quad (3-1)$$

where  $c$  = speed of light in free space (vacuum)  
 $v$  = speed of light in the medium  
 $n$  = index of refraction of the medium

The index of refraction for free space is exactly *one*. For air and most gases it is very nearly one, so in most calculations it is taken to be 1.0. For other materials it has values greater than one. Table 3-1 lists indexes of refraction for common materials.

**Table 3-1 Indexes of Refraction for Various Materials at 589 nm**

Substance	$n$	Substance	$n$
Air	1.0003	Glass (flint)	1.66
Benzene	1.50	Glycerin	1.47
Carbon Disulfide	1.63	Polystyrene	1.49
Corn Syrup	2.21	Quartz (fused)	1.46
Diamond	2.42	Sodium Chloride	1.54
Ethyl Alcohol	1.36	Water	1.33
Gallium Arsenide (semiconductor)	3.40	Ice	1.31
Glass (crown)	1.52	Germanium	4.1
Zircon	1.92	Silicon	3.5

The greater the index of refraction of a medium, the lower the speed of light in that medium and the more light is bent in going from air into the medium. Figure 3-8 shows two general cases, one for light passing from a medium of lower index to higher index, the other from higher index to lower index. Note that in the first case (lower-to-higher) the light ray is *bent toward the normal*. In the second case (higher-to-lower) the light ray is *bent away from the normal*. It is helpful to memorize these effects since they often help one trace light through optical media in a generally correct manner.

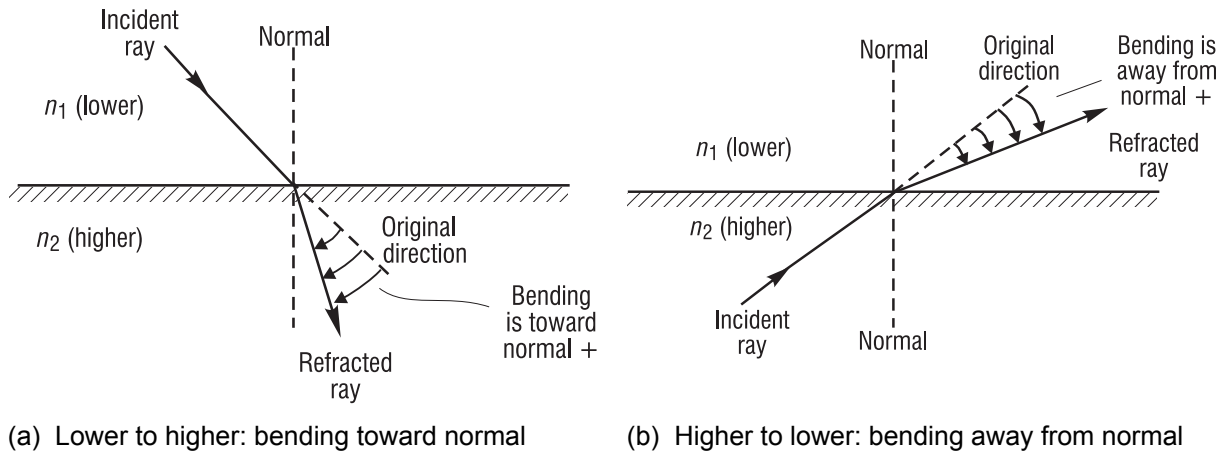

**Figure 3-8** Refraction at an interface between media of refractive indexes  $n_1$  and  $n_2$

**2. Snell's law.** *Snell's law of refraction* relates the sines of the angles of incidence and refraction at an interface between two optical media to the indexes of refraction of the two media. The law is named after a Dutch astronomer, Willebrord Snell, who formulated the law in the 17th century. Snell's law enables us to calculate the direction of the refracted ray if we know the refractive indexes of the two media and the direction of the incident ray. The mathematical expression of Snell's law and an accompanying drawing are given in Figure 3-9.

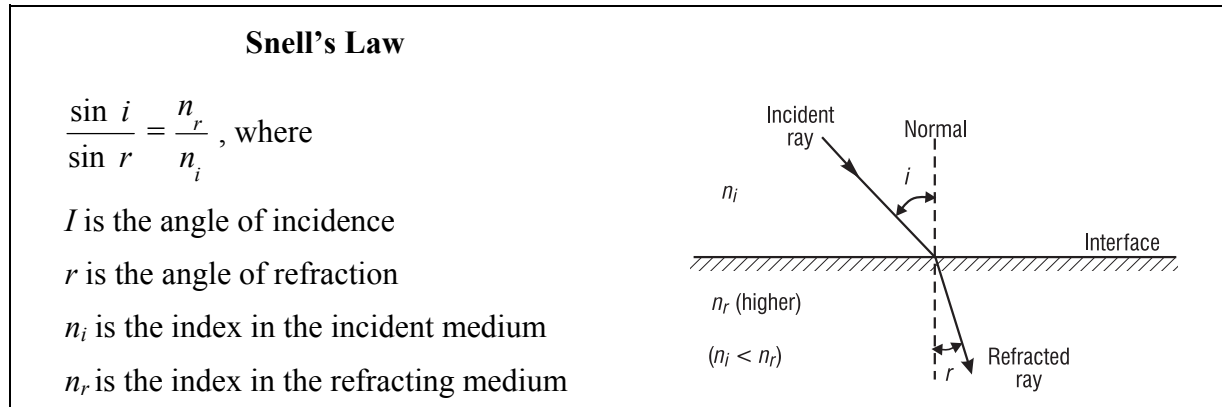

**Figure 3-9** Snell's law: formula and geometry

Note carefully that both the angle of incidence ( $i$ ) and refraction ( $r$ ) are measured with respect to the surface normal. Note also that the incident ray, normal, and refracted ray all lie in the same geometrical plane.

In practice Snell's law is often written simply as

$$n_i \sin i = n_r \sin r \quad (3-2)$$

Now let's look at an example that make use of *Snell's law*.

### Example 2

In a handheld optical instrument used under water, light is incident from water onto the plane surface of flint glass at an angle of incidence of  $45^\circ$ .

- What is the angle of reflection of light off the flint glass?
- Does the refracted ray bend toward or away from the normal?
- What is the angle of refraction in the flint glass?

#### Solution:

- From the *law of reflection*, the reflected light must head off at an angle of  $45^\circ$  with the normal. (Note: The angle of reflection is **not** dependent on the refractive indexes of the two media.)
- From Table 3-1, the index of refraction is 1.33 for water and 1.63 for flint glass. Thus, light is moving from a lower to a higher index of refraction and will bend **toward** the normal. We know then that the angle of refraction  $r$  should be less than  $45^\circ$ .
- From *Snell's law*, Equation 3-2, we have:

$$n_i \sin i = n_r \sin r$$

where  $n_i = 1.33$ ,  $i = 45^\circ$ , and  $n_r = 1.63$

$$\text{Thus, } \sin r = \frac{1.33 \sin 45^\circ}{1.63} = \frac{(1.33)(0.707)}{1.63} = 0.577$$

So  $r = \sin^{-1}(0.577) = 35.2^\circ$

The angle of refraction is about  $35^\circ$ , clearly less than  $45^\circ$ , just as was predicted in part (b).

Note: The function  $\sin^{-1}$  is of course the *arcsin*. We will use the  $\sin^{-1}$  notation since that is what is found on scientific calculators.

**3. Critical angle and total internal reflection.** When light travels from a medium of higher index to one of lower index, we encounter some interesting results. Refer to Figure 3-10, where we see four rays of light originating from point O in the higher-index medium, each incident on the interface at a different angle of incidence. Ray 1 is incident on the interface at  $90^\circ$  (normal incidence) so there is no bending.

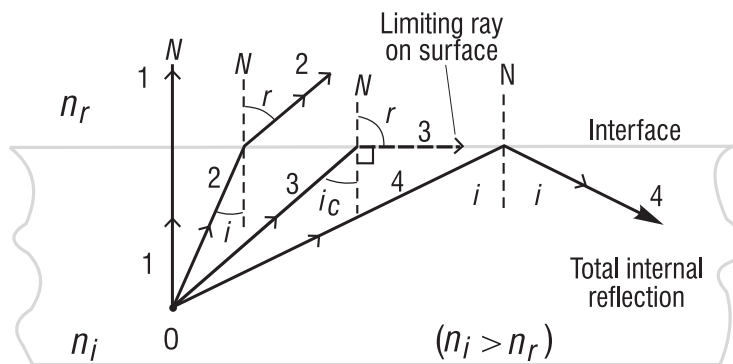

**Figure 3-10** Critical angle and total internal reflection

The light in this direction simply speeds up in the second medium (why?) but continues along the same direction. Ray 2 is incident at angle  $i$  and refracts (bends away from the normal) at angle  $r$ . Ray 3 is incident at the *critical angle*  $i_c$ , large enough to cause the refracted ray bending away from the normal (N) to bend by  $90^\circ$ , thereby traveling along the interface between the two media. (This ray is trapped in the interface.) Ray 4 is incident on the interface at an angle *greater than* the critical angle, and is *totally reflected* into the same medium from which it came. Ray 4 obeys the *law of reflection* so that its angle of reflection is exactly equal to its angle of incidence. We exploit the phenomenon of total internal reflection when designing light propagation in fibers by trapping the light in the fiber through successive internal reflections along the fiber. We do this also when designing “retroreflecting” prisms. Compared with ordinary reflection from mirrors, the sharpness and brightness of totally internally reflected light beams is enhanced considerably.

The calculation of the critical angle of incidence for any two optical media—whenever light is incident from the medium of higher index—is accomplished with *Snell’s law*. Referring to Ray 3 in Figure 3-10 and using Snell’s law in Equation 3-2 appropriately, we have

$$n_i \sin i_c = n_r \sin 90^\circ$$

where  $n_i$  is the index for the incident medium,  $i_c$  is the critical angle of incidence,  $n_r$  is the index for the medium of lower index, and  $r = 90^\circ$  is the angle of refraction at the critical angle. Then, since  $\sin 90^\circ = 1$ , we obtain for the critical angle,

$$i_c = \sin^{-1} \left( \frac{n_r}{n_i} \right) \quad (3-3)$$

Let's use this result and Snell's law to determine the entrance cone for light rays incident on the face of a clad fiber if the light is to be trapped by total internal reflection at the core-cladding interface in the fiber.

### Example 3

A step-index fiber 0.0025 inch in diameter has a core index of 1.53 and a cladding index of 1.39. See drawing. Such clad fibers are used frequently in applications involving communication, sensing, and imaging.

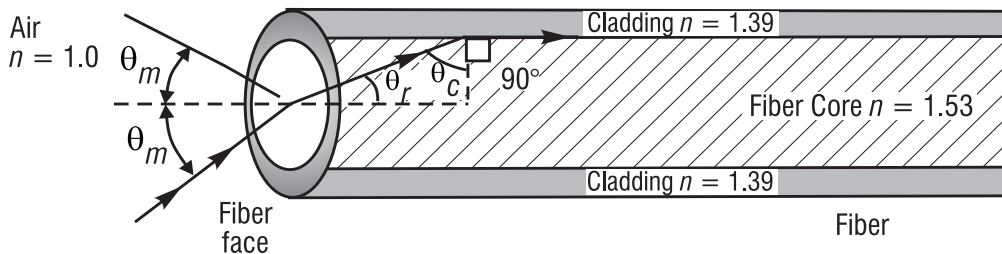

What is the maximum acceptance angle  $\theta_m$  for a cone of light rays incident on the fiber face such that the refracted ray in the core of the fiber is incident on the cladding at the critical angle?

**Solution:** First find the critical angle  $\theta_c$  in the core, at the core-cladding interface. Then, from geometry, identify  $\theta_r$  and use Snell's law to find  $\theta_m$ .

(1) From Equation 3-3, at the core-cladding interface

$$\theta_c = \sin^{-1} \left( \frac{1.39}{1.53} \right) = 65.3^\circ$$

(2) From right-triangle geometry,  $\theta_r = 90 - 65.3 = 24.7^\circ$

(3) From Snell's law, at the fiber face,

$$n_{air} \sin \theta_m = n_{core} \sin \theta_r$$

$$\text{and} \quad \sin \theta_m = \left( \frac{n_{core}}{n_{air}} \right) \sin \theta_r = \left( \frac{1.53}{1.00} \right) \sin (24.7^\circ)$$

$$\text{from which} \quad \sin \theta_m = 0.639$$

$$\text{and} \quad \theta_m = \sin^{-1} 0.639 = 39.7^\circ$$

Thus, the maximum acceptance angle is  $39.7^\circ$  and the acceptance cone is twice that, or  $2\theta_m = 79.4^\circ$ . The acceptance cone indicates that any light ray incident on the fiber face within the acceptance angle will undergo total internal reflection at the core-cladding face and remain trapped in the fiber as it propagates along the fiber.

### D. Refraction in prisms

Glass prisms are often used to bend light in a given direction as well as to bend it back again (retroreflection). The process of refraction in prisms is understood easily with the use of light rays and Snell's law. Look at Figure 3-11a. When a light ray enters a prism at one face and exits at another, the exiting ray is *deviated* from its original direction. The prism shown is isosceles in cross section with *apex angle*  $A = 30^\circ$  and refractive index  $n = 1.50$ . The incident angle  $\theta$  and the *angle of deviation*  $\delta$  are shown on the diagram.

Figure 3-11b shows how the angle of deviation  $\delta$  changes as the angle  $\theta$  of the incident ray changes. The specific curve shown is for the prism described in Figure 3-11a. Note that  $\delta$  goes through a minimum value, about  $23^\circ$  for this specific prism. Each prism material has its own unique *minimum angle of deviation*.

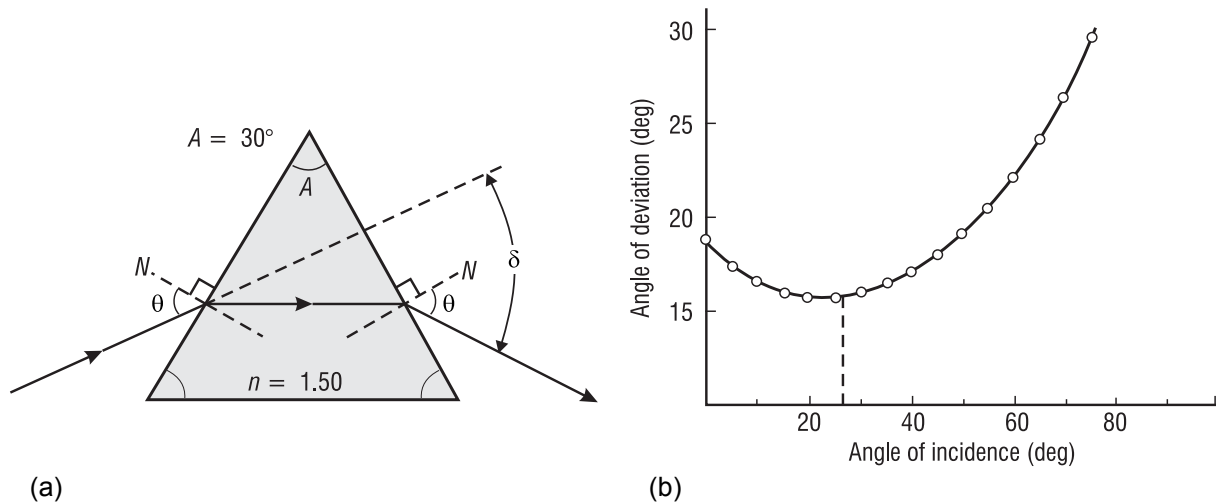

**Figure 3-11** Refraction of light through a prism

**1. Minimum angle of deviation.** It turns out that we can determine the refractive index of a transparent material by shaping it in the form of an isosceles prism and then measuring its *minimum* angle of deviation. With reference to Figure 3-11a, the relationship between the refractive index  $n$ , the prism apex angle  $A$ , and the minimum angle of deviation  $\delta_m$  is given by

$$n = \frac{\sin\left(\frac{A + \delta_m}{2}\right)}{\sin\frac{A}{2}} \tag{3-4}$$

where both  $A$  and  $\delta_m$  are measured in degrees.

The derivation of Equation 3-4 is straightforward, but a bit tedious. Details of the derivation—making use of Snell's law and geometric relations between angles at each refracting surface—can be found in most standard texts on geometrical optics. (See suggested references at the end of the module.) Let's show how one can use Equation 3-4 in Example 4 to determine the index of refraction of an unknown glass shaped in the form of a prism.

**Example 4**

A glass of unknown index of refraction is shaped in the form of an isosceles prism with an apex angle of  $25^\circ$ . In the laboratory, with the help of a laser beam and a prism table, the *minimum* angle of deviation for this prism is measured carefully to be  $15.8^\circ$ . What is the refractive index of this glass material?

**Solution:** Given that  $\delta_m = 15.8^\circ$  and  $A = 25^\circ$ , we use Equation 3-4 to calculate the refractive index.

$$n = \frac{\sin\left(\frac{A + \delta_m}{2}\right)}{\sin\left(\frac{A}{2}\right)} = \frac{\sin\left(\frac{25^\circ + 15.8^\circ}{2}\right)}{\sin\left(\frac{25^\circ}{2}\right)} = \frac{\sin(20.4^\circ)}{\sin(12.5^\circ)} = \frac{0.3486}{0.2164}$$

$$n = 1.61$$

(Comparing this value with refractive indexes given in Table 3-1, the unknown glass is probably flint glass.)

**2. Dispersion of light.** Table 3-1 lists indexes of refraction for various substances independent of the wavelength of the light. In fact, the refractive index is slightly wavelength dependent. For example, the index of refraction for flint glass is about 1% higher for blue light than for red light. The variation of refractive index  $n$  with wavelength  $\lambda$  is called *dispersion*. Figure 3-12a shows a normal dispersion curve of  $n_\lambda$  versus  $\lambda$  for different types of optical glass. Figure 3-12b shows the separation of the individual colors in white light—400 nm to 700 nm—after passing through a prism. Note that  $n_\lambda$  decreases from short to long wavelengths, thus causing the red light to be less deviated than the blue light as it passes through a prism. This type of dispersion that accounts for the colors seen in a rainbow, the “prism” there being the individual raindrops.

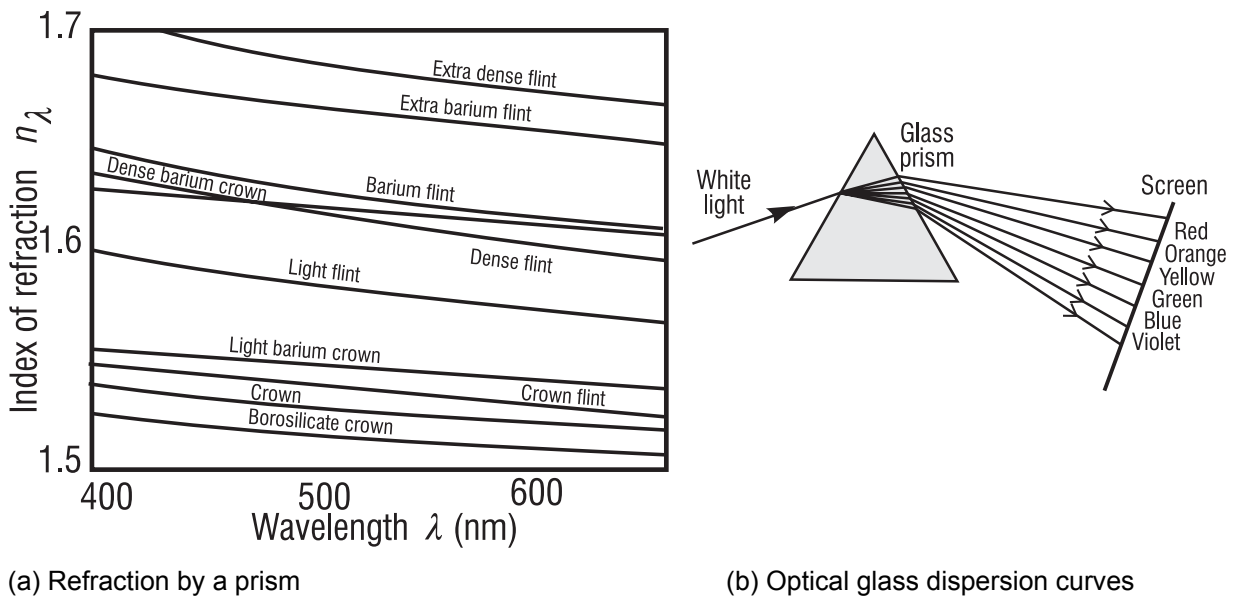

**Figure 3-12** Typical dispersion curves and separation of white light after refraction by a prism



**3. Special applications of prisms.** Prisms that depend on *total internal reflection* are commonly used in optical systems, both to change direction of light travel and to change the orientation of an image. While mirrors can be used to achieve similar ends, the reflecting faces of a prism are easier to keep free of contamination and the process of total internal reflection is capable of higher reflectivity. Some common prisms in use today are shown in Figure 3-13, with details of light redirection and image reorientation shown for each one. If, for example, the Dove prism in Figure 3-13b is rotated about its long axis, the image will also be rotated.

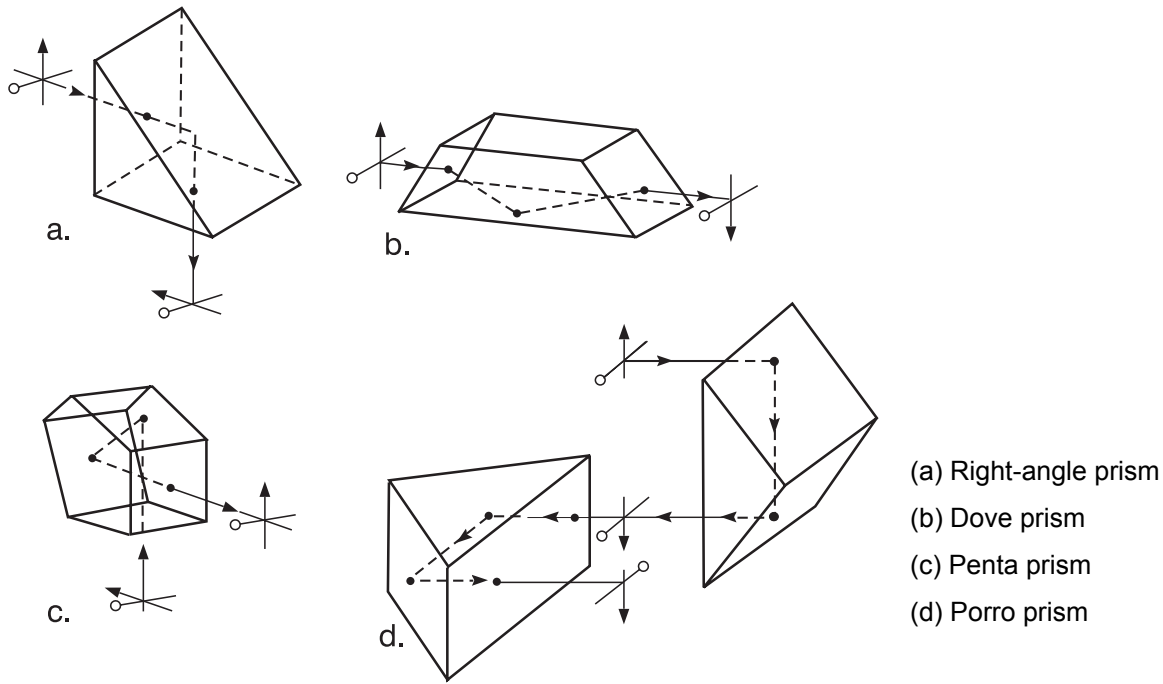

**Figure 3-13** Image manipulation with refracting prisms

The Porro prism, consisting of two right-angle prisms, is used in binoculars, for example, to produce erect final images and, at the same time, permit the distance between the object-viewing lenses to be greater than the normal eye-to-eye distance, thereby enhancing the stereoscopic effect produced by ordinary binocular vision.

## II. IMAGE FORMATION WITH MIRRORS

Mirrors, of course, are everywhere—in homes, auto headlamps, astronomical telescopes, and laser cavities, and many other places. Plane and spherical mirrors are used to form three-dimensional images of three-dimensional objects. If the size, orientation, and location of an object relative to a mirror are known, the *law of reflection* and ray tracing can be used to locate the image graphically. Appropriate mathematical formulas can also be used to calculate the locations and sizes of the images formed by mirrors. In this section we shall use both graphical ray tracing and formulas.

## A. Images formed with plane mirrors

Images with mirrors are formed when many nonparallel rays from a given point on a source are reflected from the mirror surface, converge, and form a corresponding image point. When this happens, point by point for an extended object, an image of the object, point by point, is formed. Image formation in a plane mirror is illustrated in several sketches shown in Figure 3-14.

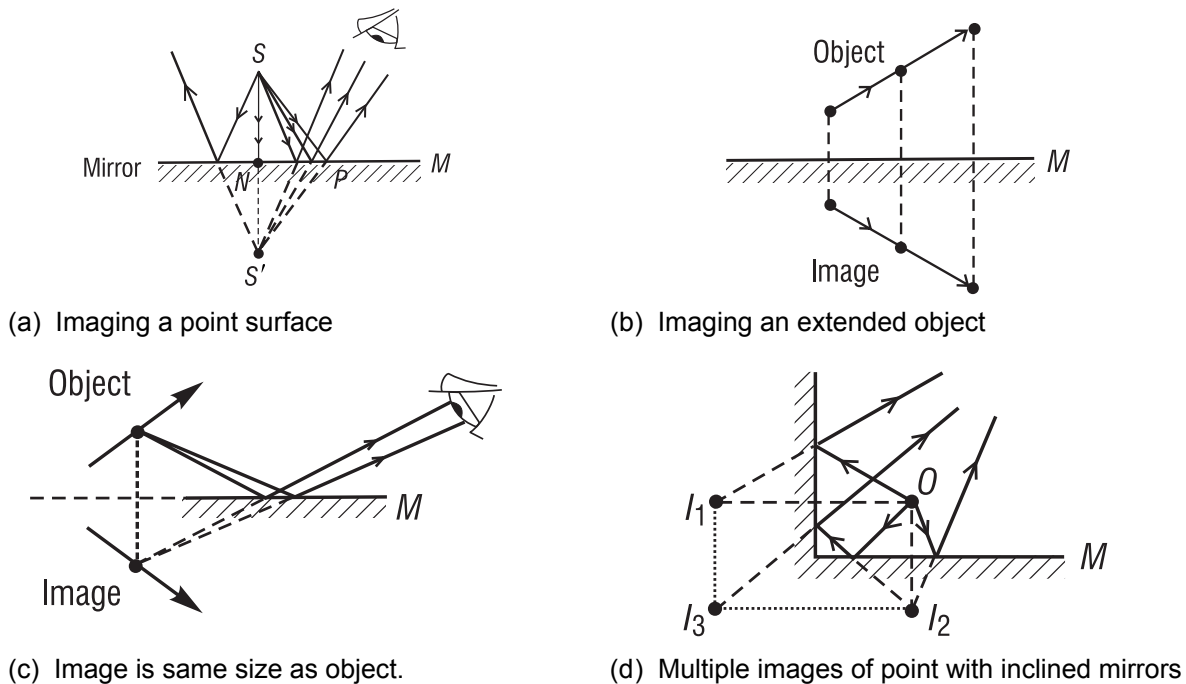

**Figure 3-14** Image formation in a plane mirror

In Figure 3-14a, point object  $S$  sends nonparallel rays toward a plane mirror, which reflects them as shown. The *law of reflection* ensures that pairs of triangles like  $SNP$  and  $S'NP$  are equal, so that all reflected rays appear to originate at the *image point*  $S'$ , which lies along the normal line  $SN$ , and at such depth that the *image distance*  $S'N$  equals the *object distance*  $SN$ . The eye sees a point image at  $S'$  in exactly the same way it would see a real point object placed there. Since the actual rays do not exist below the mirror surface, the image is said to be a *virtual image*. The image  $S'$  cannot be projected on a screen as in the case of a *real image*. An extended object, such as the arrow in Figure 3-14b, is imaged point by point by a plane mirror surface in similar fashion. Each object point has its image point along its normal to the mirror surface and *as far below the reflecting surface as the object point lies above the surface*. Note that image position does not depend on the position of the eye.

The construction in Figure 3-14b also makes clear that the image size is identical to the object size, giving a *magnification* of unity. In addition, the transverse orientations of object and image are the same. A right-handed object, however, appears left-handed in its image. In Figure 3-14c, where the mirror does not lie directly below the object, the mirror plane may be extended to determine the position of the image as seen by an eye positioned to receive reflected rays originating at the object. Figure 3-14d illustrates multiple images of a point object  $O$  formed by two perpendicular mirrors. Each image,  $I_1$  and  $I_2$ , results from a single reflection in one of the

two mirrors, but a third image  $I_3$  is also present, formed by sequential reflections from both mirrors. All parts of Figure 3-14 and the related discussion above should be understood clearly because they are fundamental to the optics of images. Look at Example 5.

**Example 5**

Making use of the *law of reflection* and the conclusions drawn from Figure 3-14, draw the image of the letter  $L$  positioned above a plane mirror as shown below in (a).

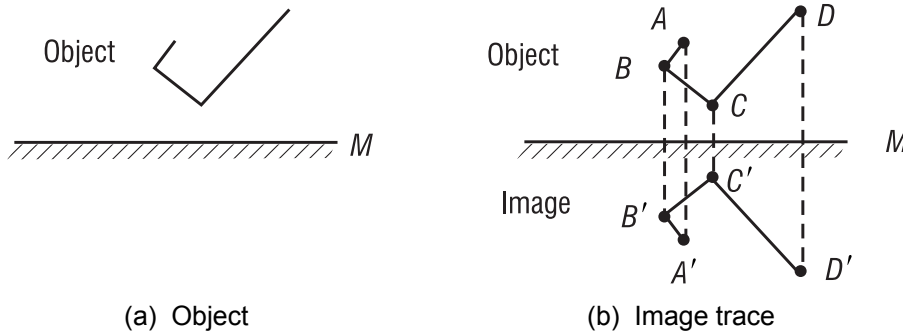

**Solution:** Make use of the fact that each point on the image is as far below the mirror—along a line perpendicular to the mirror—as the actual object point is above the mirror. Indicate key points on the object and locate corresponding points on the image. Sketch in the image as shown in (b).

**B. Images formed with spherical mirrors**

As we showed earlier in Figure 3-6, the *law of reflection* can be used to determine the direction along which any ray incident on a spherical mirror surface will be reflected. Using the *law of reflection*, we can trace rays from any point on an object to the mirror, and from there on to the corresponding image point. This is the method of *graphical ray tracing*.

**1. Graphical ray-trace method.** To employ the method of ray tracing, we agree on the following:

- Light will be incident on a mirror surface *initially* from the left.
- The axis of symmetry normal to the mirror surface is its *optical axis*.
- The point where the optical axis meets the mirror surface is the *vertex*.

To locate an image we use two points common to each mirror surface, the *center of curvature*  $C$  and the *focal point*  $F$ . They are shown in Figure 3-15, with the mirror vertex  $V$ , for both a *concave* and a *convex* spherical mirror.

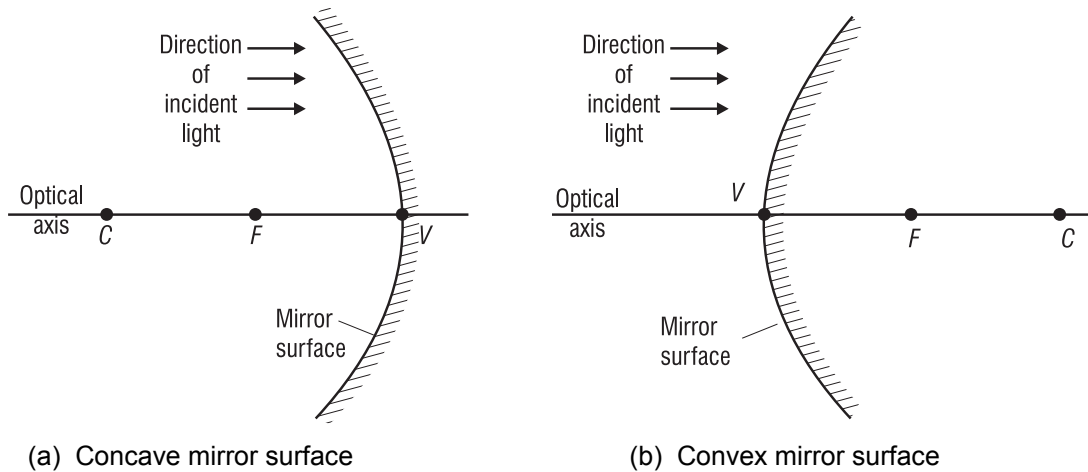

**Figure 3-15** Defining points for concave and convex mirrors

The edges of *concave* mirrors always bend toward the oncoming light. Such mirrors have their center of curvature  $C$  and focal point  $F$  located to the *left* of the vertex as seen in Figure 3-15a. The edges of *convex* mirrors always bend away from the oncoming light, and their center of curvature  $C$  and focal point  $F$  are located to the *right* of the vertex. See Figure 3-15b.

The important connection between parallel rays and the focal points for mirror surfaces is shown in Figure 3-16 a, b. Parallel rays are light rays coming from a very distant source (such as the sun) or from a collimated laser beam. The *law of reflection*, applied at each point on the mirror surface where a ray is incident, requires that the ray be reflected so as to pass through a focal point  $F$  in front of the mirror (Figure 3-16a) or be reflected to appear to come from a focal point  $F$  behind the mirror (Figure 3-16b). Notice that a line drawn from the center of curvature  $C$  to any point on the mirror is a *normal* line and thus bisects the angle between the incident and reflected rays. As long as the transverse dimension of the mirror is not too large, simple geometry shows that the point  $F$ , for either mirror, is located at the midpoint between  $C$  and  $V$ , so that the distance  $FV$  is one-half the radius of curvature  $CV$ . The distance  $FV$  is called the *focal length* and is commonly labeled as  $f$ .

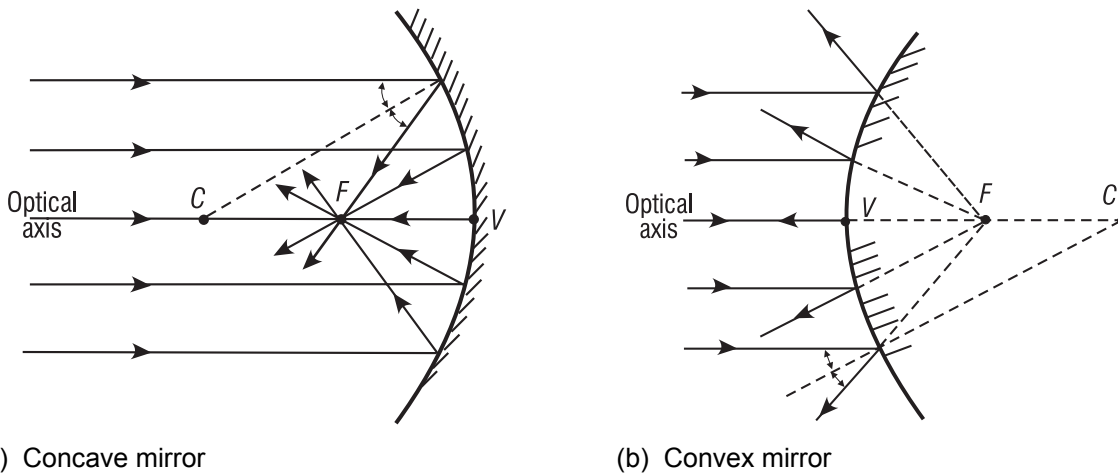

**Figure 3-16** Parallel rays and focal points

**2. Key rays used in ray tracing.** Figure 3-17 shows three key rays—for each mirror—that are used to locate an image point corresponding to a given object point. They are

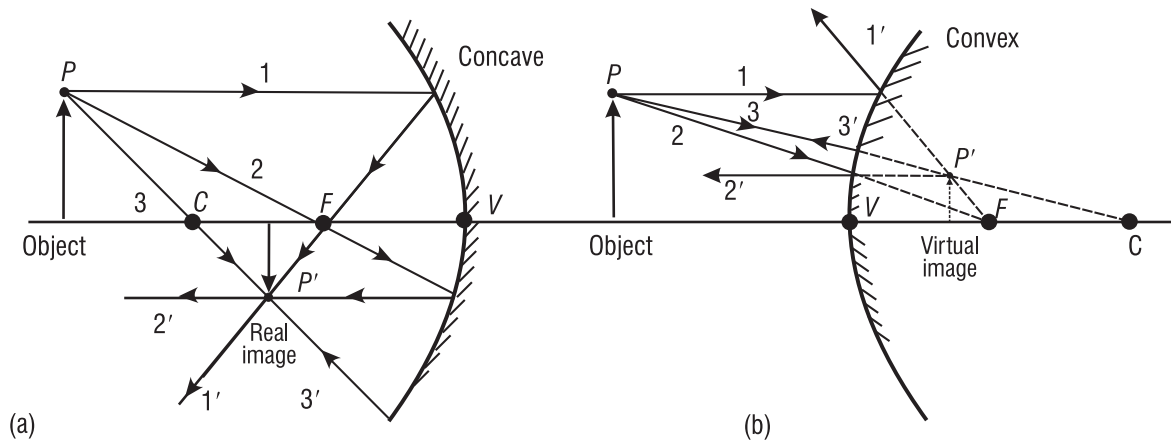

**Figure 3-17** Key rays for graphical ray tracing with spherical mirrors

labeled 1, 2, and 3. Any two, drawn from object point  $P$ , will locate the corresponding image point  $P'$ . In most cases it is sufficient to locate one point, like  $P'$ , to be able to draw the entire image. Note carefully, with reference to Figure 3-17a, b, the following facts:

**For a concave mirror:**

- The ray from object point  $P$  parallel to the axis, such as ray 1, reflects from the mirror and *passes through the focal point  $F$*  (labeled ray 1').
- The ray from  $P$  passing through the focal point  $F$ , such as ray 2, reflects from the mirror *as a ray parallel to the axis* (labeled ray 2').
- The ray from  $P$  passing through the center of curvature  $C$ , such as ray 3, *reflects back along itself* (labeled ray 3').
- Reflected rays 1', 2', and 3' converge to locate point  $P'$  on the image. This image is a *real image* that can be formed on a screen located there.

**For a convex mirror:**

- The ray from object point  $P$ , parallel to the axis, such as ray 1, reflects from the mirror *as if to come from the focal point  $F$  behind the mirror* (labeled ray 1').
- The ray from  $P$ , such as ray 2, headed toward the focal point  $F$  behind the mirror, reflects from the mirror in a direction parallel to the optical axis (labeled ray 2').
- The ray from  $P$ , such as ray 3, headed toward the center of curvature  $C$  behind the mirror, reflects back along itself (labeled ray 3').
- Rays 1', 2', and 3' diverge after reflection. A person looking toward the mirror intercepts the diverging rays and sees them appearing to come from their common intersection point  $P'$ , behind the mirror. The image is *virtual* since it cannot be formed on a screen placed there.

### Example 6

The passenger-side mirror on an automobile is a *convex* mirror. It provides the driver with a wide field of view, but significantly reduced images. Assume that object  $OP$  is part of an automobile trailing the driver's car. See diagram below. Use three key rays to locate the reduced, virtual image of the trailing auto.

**Solution:** Using key rays 1, 2, and 3 incident on the mirror from point  $P$  on object  $OP$ , in conjunction with points  $C$  and  $F$ , draw the appropriate reflected rays, as show below, to locate  $P'$  on image  $IP'$ .

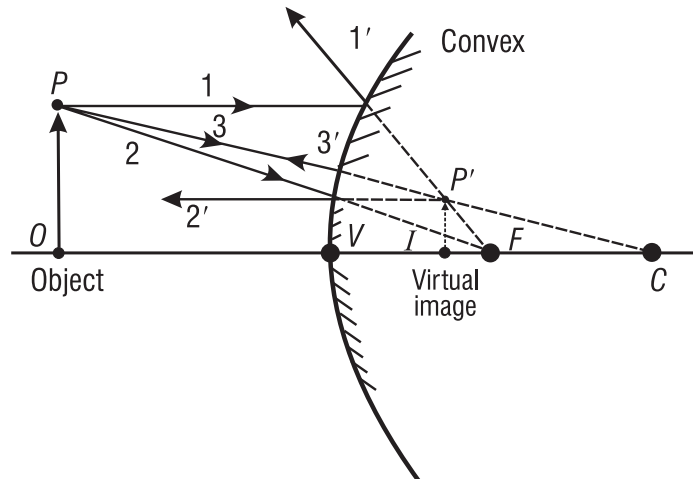

The three reflected rays  $1'$ ,  $2'$ , and  $3'$  *diverge* after reflection. They appear to come from a common point  $P'$  *behind* the mirror. This locates *virtual image*  $IP'$ , reduced in size, about one-third as large as object  $OP$ . As a result, drivers are always cautioned that images seen in the passenger-side mirror are actually NEARER than they appear to be.

## C. Mirror formulas for image location

In place of the graphical ray-tracing methods described above, we can use formulas to calculate the image location. We shall derive below a “mirror formula” and then use the formula to determine image location. The derivation is typical of those found in geometrical optics, and is instructive in its combined use of algebra, geometry, and trigonometry. (If the derivation is not of interest to you, you may skip to the next section, where the derived formula is used in typical calculations. Be sure, though, that you learn about the sign convention discussed below.)

**1. Derivation of the mirror formula.** The drawing we need to carry out the derivation is shown in Figure 3-18. The important quantities are the object distance  $p$ , the image distance  $q$ , and the radius of curvature  $r$ . Both  $p$  and  $q$  are measured relative to the mirror vertex, as shown, and the sign on  $r$  will indicate whether the mirror is concave or convex. All other quantities in Figure 3-18 are used in the derivation but will not show up in the final “mirror formula.”

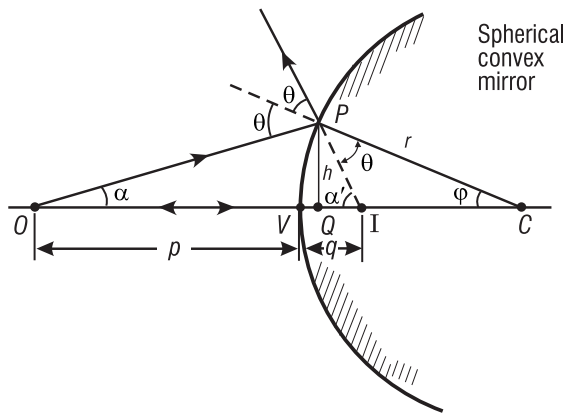

Figure 3-18 Basic drawing for deriving the mirror formula

The mirror shown in Figure 3-18 is convex with center of curvature  $C$  on the right. Two rays of light originating at object point  $O$  are drawn, one normal to the convex surface at its vertex  $V$  and the other an arbitrary ray incident at  $P$ . The first ray reflects back along itself; the second reflects at  $P$  as if incident on a plane tangent at  $P$ , according to the *law of reflection*. Relative to each other, the two reflected rays diverge as they leave the mirror. The intersection of the two rays (extended backward) determines the image point  $I$  corresponding to object point  $O$ . The image is virtual and located behind the mirror surface.

Object and image distances measured from the vertex  $V$  are shown as  $p$  and  $q$ , respectively. A perpendicular of height  $h$  is drawn from  $P$  to the axis at  $Q$ . We seek a relationship between  $p$  and  $q$  that depends on only the radius of curvature  $r$  of the mirror. As we shall see, such a relation is possible only to a first-order approximation of the sines and cosines of angles such as  $\alpha$  and  $\phi$  made by the object and image rays at various points on the spherical surface. This means that, in place of expansions of  $\sin \phi$  and  $\cos \phi$  in series as shown here,

$$\sin \phi = \phi - \frac{\phi^3}{3!} + \frac{\phi^5}{5!} - \dots$$

$$\cos \phi = 1 - \frac{\phi^2}{2!} + \frac{\phi^4}{4!} - \dots$$

we consider the first terms only and write

$$\sin \phi \cong \phi \quad \text{and} \quad \cos \phi \cong 1, \quad \text{so that} \quad \tan \phi = \frac{\sin \phi}{\cos \phi} \cong \phi$$

These relations are accurate to 1% or less if the angle  $\phi$  is  $10^\circ$  or smaller. This approximation leads to *first-order (or Gaussian) optics*, after Karl Friedrich Gauss, who in 1841 developed the foundations of this subject. Returning now to the problem at hand—that of relating  $p$ ,  $q$ , and  $r$ —notice that two angular relationships may be obtained from Figure 3-18, because the exterior angle of a triangle equals the sum of its interior angles. Thus,

$$\theta = \alpha + \phi \quad \text{in } \triangle OPC \quad \text{and} \quad 2\theta = \alpha + \alpha' \quad \text{in } \triangle OPI$$

which combine to give

$$\alpha - \alpha' = 2\phi$$

Using the small-angle approximation, the angles  $\alpha$ ,  $\alpha'$ , and  $\varphi$  above can be replaced by their tangents, yielding

$$\frac{h}{p} - \frac{h}{q} = -2 \frac{h}{r}$$

Note that we have neglected the axial distance  $VQ$ , small when  $\varphi$  is small. Cancellation of  $h$  produces the desired relationship,

$$\frac{1}{p} - \frac{1}{q} = -\frac{2}{r} \quad (3-5)$$

If the spherical surface is chosen to be concave instead, the center of curvature will be to the left. For certain positions of the object point  $O$ , it is then possible to find a real image point, also to the left of the mirror. In these cases, the resulting geometric relationship analogous to Equation 3-5 consists of the same terms, but with different algebraic signs, depending on the *sign convention* employed. We can choose a sign convention that leads to a single equation, the *mirror equation*, valid for both types of mirrors. It is Equation 3-6.

$$\boxed{\frac{1}{p} + \frac{1}{q} = -\frac{2}{r}} \quad (3-6)$$

**2. Sign convention.** The sign convention to be used in conjunction with Equation 3-6 and Figure 3-18 is as follows.

- Object and image distances  $p$  and  $q$  are both *positive* when located to the *left* of the vertex and both *negative* when located to the *right*.
- The radius of curvature  $r$  is *positive* when the center of curvature  $C$  is to the *left* of the vertex (concave mirror surface) and *negative* when  $C$  is to the *right* (convex mirror surface).
- Vertical dimensions are positive above the optical axis and negative below.

In the application of these rules, light is assumed to be directed initially, as we mentioned earlier, from left to right. According to this sign convention, *positive* object and image distances correspond to *real* objects and images, and *negative* object and image distances correspond to *virtual* objects and images. *Virtual objects* occur only with a sequence of two or more reflecting or refracting elements.

**3. Magnification of a mirror image.** Figure 3-19 shows a drawing from which the *magnification*—ratio of image height  $h_i$  to object height  $h_o$ —can be determined. Since angles  $\theta_i$ ,  $\theta_r$ , and  $\alpha$  are equal, it follows that triangles  $VOP$  and  $VIP'$  are similar. Thus, the sides of the two triangles are proportional and one can write

$$\frac{h_i}{h_o} = \frac{q}{p}$$

This gives at once the magnification  $m$  to be

$$m \equiv \frac{h_i}{h_o} = \frac{q}{p}$$



## BASIC GEOMETRICAL OPTICS

When the *sign convention* is taken into account, one has, for the *general case*, a single equation, Equation 3-7, valid for both convex and concave mirrors.

$$m = -\frac{q}{p} \quad (3-7)$$

If, after calculation, the value of  $m$  is positive, the image is erect. If the value is negative, the image is inverted.

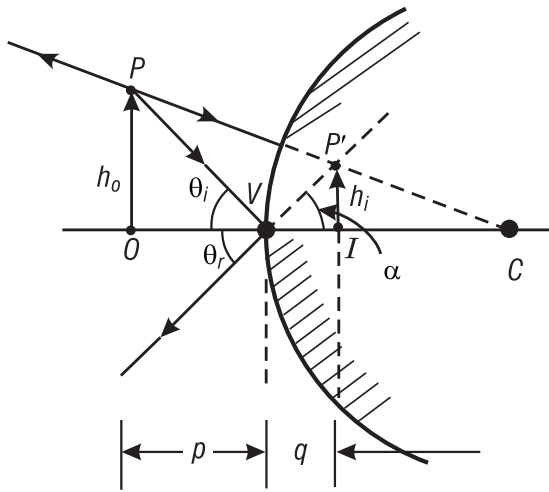
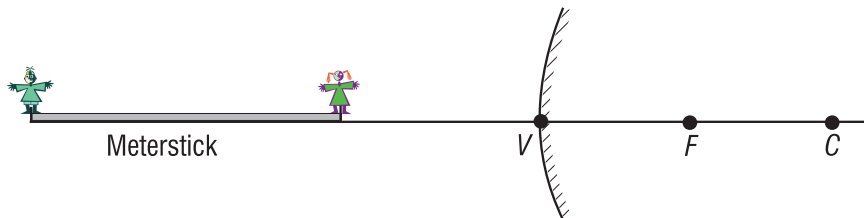

**Figure 3-19** Construction for derivation of mirror magnification formula

Let us now use the mirror formulas in Equations 3-6 and 3-7, and the sign convention, to locate an image and determine its size.

### Example 7

A meterstick lies along the optical axis of a convex mirror of focal length 40 cm, with its near end 60 cm from the mirror surface. Five-centimeter toy figures stand erect on both the near and far ends of the meterstick. (a) How long is the virtual image of the meterstick? (b) How tall are the toy figures in the image, and are they erect or inverted?



**Solution:** Use the mirror equation  $\frac{1}{p} + \frac{1}{q} = -\frac{2}{r}$  twice, once for the near end and once for the far

end of the meterstick. Use the magnification equation  $m = -\frac{q}{p}$  for each toy figure.

(a) **Near end:** Sign convention gives  $p = +60$  cm,  $r = 2f = -(2 \times 40) = -80$  cm

$$\therefore \frac{1}{60} + \frac{1}{q_n} = -\frac{2}{80}, \text{ so } q_n = -24 \text{ cm}$$

Negative sign indicates image is *virtual*, 24 cm to the right of  $V$ .

**Far end:**  $p = +160$  cm,  $r = -80$  cm

$$\frac{1}{160} + \frac{1}{q_f} = -\frac{1}{40}, \text{ so } q_f = -32 \text{ cm}$$

Far-end image is *virtual*, 32 cm to the right of  $V$ .

$\therefore$  Meterstick image is  $32 \text{ cm} - 24 \text{ cm} = 8 \text{ cm}$  long.

(b) **Near-end toy figure:**

$$m_n = \frac{-q}{p} = \frac{-(-24)}{60} = +0.4 \text{ (Image is erect since } m \text{ is positive.)}$$

The toy figure is  $5 \text{ cm} \times 0.4 = 2 \text{ cm}$  tall, at near end of the meterstick image.

**Far-end toy figure:**

$$m_f = \frac{-q}{p} = \frac{-(-32)}{160} = +0.2 \text{ (Image is erect since } m \text{ is positive.)}$$

The toy figure is  $5 \text{ cm} \times 0.2 = 1 \text{ cm}$  tall, at far end of the meterstick image.

### III. IMAGE FORMATION WITH LENSES

Lenses are at the heart of many optical devices, not the least of which are cameras, microscopes, binoculars, and telescopes. Just as the *law of reflection* determines the imaging properties of mirrors, so *Snell's law of refraction* determines the imaging properties of lenses. Lenses are essentially light-controlling elements, used primarily for image formation with visible light, but also for ultraviolet and infrared light. In this section we shall look first at the types and properties of lenses, then use graphical ray-tracing techniques to locate images, and finally use mathematical formulas to locate the size, orientation, and position of images in simple lens systems.

#### A. Function of a lens

A lens is made up of a transparent refracting medium, generally of some type of glass, with spherically shaped surfaces on the front and back. A ray incident on the lens refracts at the front surface (according to Snell's law) propagates through the lens, and refracts again at the rear surface. Figure 3-20 shows a rather thick lens refracting rays from an object  $OP$  to form an image  $O'P'$ . The ray-tracing techniques and lens formulas we shall use here are based again on *Gaussian optics*, just as they were for mirrors.

## BASIC GEOMETRICAL OPTICS

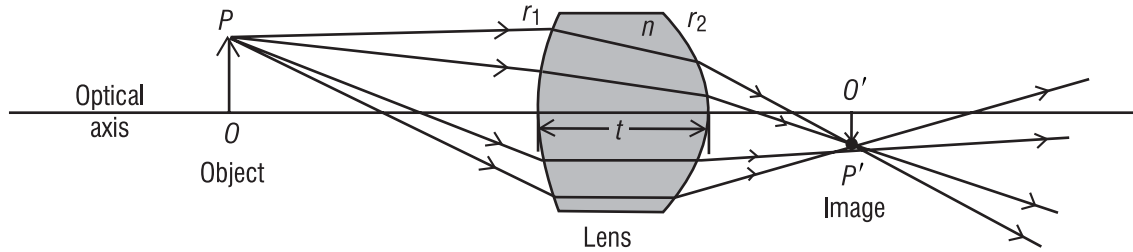

**Figure 3-20** Refraction of light rays by a lens

As we have seen, *Gaussian optics*—sometimes called *paraxial optics*—arises from the basic approximations  $\sin \varphi \cong \varphi$ ,  $\tan \varphi \cong \varphi$ , and  $\cos \varphi \cong 1$ . These approximations greatly simplify ray tracing and lens formulas, but they do restrict the angles the light rays make with the optical axis to rather small values of  $20^\circ$  or less.

### B. Types of lenses

If the axial thickness of a lens is small compared with the radii of curvature of its surfaces, it can be treated as a *thin* lens. Ray-tracing techniques and lens formulas are relatively simple for thin lenses. If the thickness of a lens is not negligible compared with the radii of curvature of its faces, it must be treated as a *thick* lens. Ray-tracing techniques and lens-imaging formulas are more complicated for thick lenses, where computer programs are often developed to trace the rays through the lenses or make surface-by-surface calculations. In this basic introduction of geometrical optics, we shall deal with only thin lenses.

**1. Converging and diverging thin lenses.** In Figure 3-21, we show the shapes of several common “thin” lenses. Even though a “thickness” is shown, the use of thin lenses assumes that the rays simply refract at the front and rear faces without a translation through the lens medium. The first three lenses are *thicker in the middle than at the edges* and are described as *converging* or *positive* lenses. They are converging because they cause parallel rays passing through them to bend toward one another. Such lenses give rise to positive focal lengths. The last three lenses are *thinner in the middle than at the edges* and are described as *diverging* or *negative* lenses. In contrast with converging lenses, they cause parallel rays passing through them to spread as they leave the lens. These lenses give rise to negative focal lengths. In Figure 3-21, names associated with the different shapes are noted.

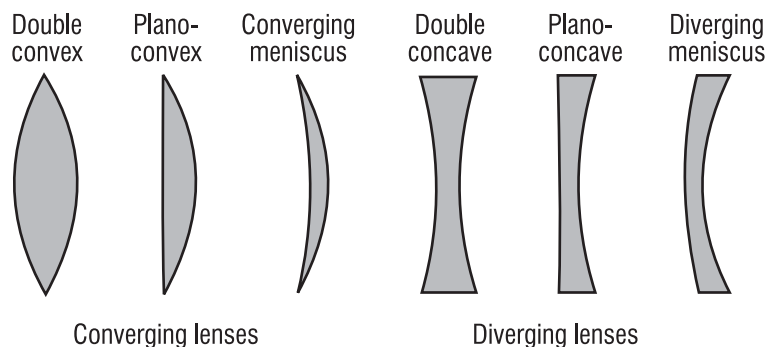

**Figure 3-21** Shapes of common thin lenses

**2. Focal points of thin lenses.** Just as for mirrors, the *focal points* of lenses are defined in terms of their effect on parallel light rays and plane wave fronts. Figure 3-22 shows parallel light rays and their associated plane wave fronts incident on a *positive* lens (Figure 3-22a) and a *negative* lens (Figure 3-22b). For the positive lens, refraction of the light brings it to focal point  $F$  (real image) to the right of the lens. For the negative lens, refraction of the light causes it to diverge as if it is coming from focal point  $F$  (virtual image) located to the left of the lens. Note how the plane wave fronts are changed to converging spherical wave fronts by the positive lens and to diverging spherical wave fronts by the negative lens. This occurs because light travels more slowly in the lens medium than in the surrounding air, so the thicker parts of the lens retard the light more than do the thinner parts.

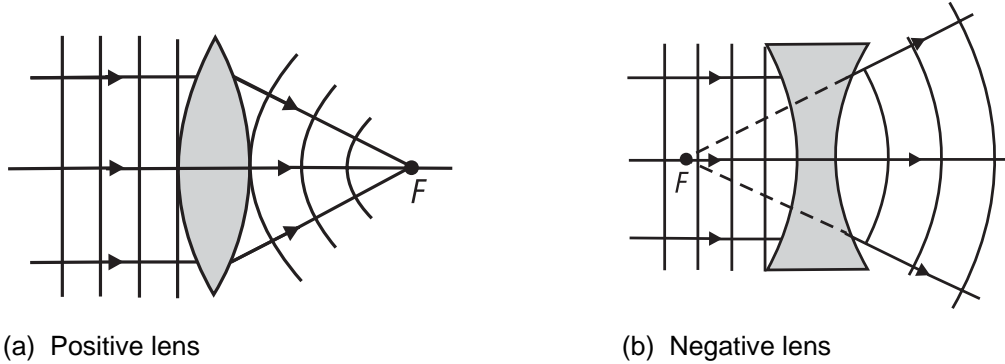

**Figure 3-22** Focal points for positive and negative lenses

Recall that, for mirrors, there is but a *single* focal point for each mirror surface since light remains always on the same side of the mirror. For thin lenses, there are *two* focal points, symmetrically located on each side of the lens, since light can approach from either side of the lens. The sketches in Figure 3-23 indicate the role that the two focal points play, for positive lenses (Figure 3-23a) and negative lenses (Figure 3-23b). Study these figures carefully.

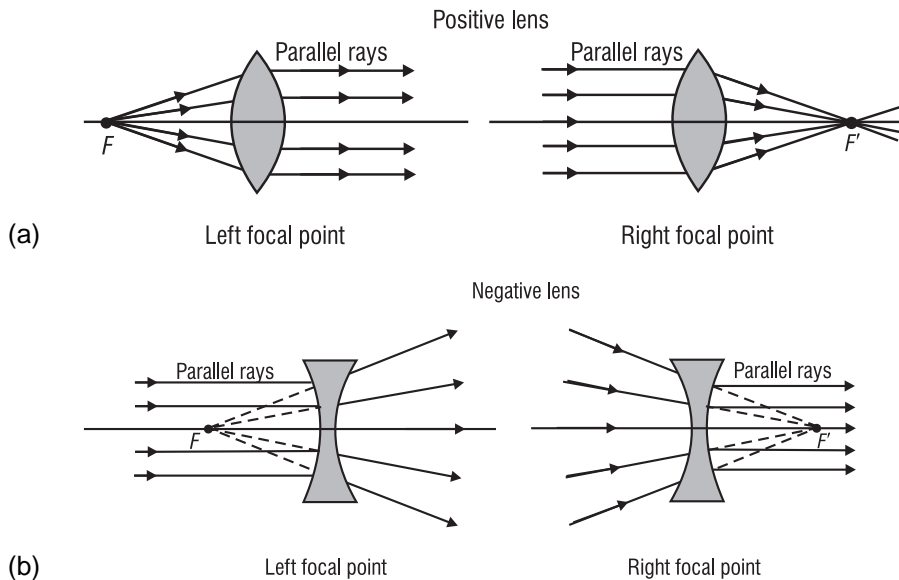

**Figure 3-23** Relationship of light rays to right and left focal points in thin lenses

**3. *f*-number and numerical aperture of a lens.** The size of a lens determines its light-gathering power and, consequently, the brightness of the image it forms. Two commonly used indicators of this special characteristic of a lens are called the *f*-number and the *numerical aperture*.

The *f*-number, also referred to as the *relative aperture* and the *f/stop*, is defined simply as the ratio of the focal length *f* of the lens, to its diameter *D*, as given in Equation 3-8.

$$\boxed{f\text{-number} = \frac{f}{D}} \quad (3-8)$$

For example, a lens of focal length 4 cm *stopped down* to an aperture of 0.5 cm has an *f*-number of  $4/0.5 = 8$ . Photographers usually refer to this situation as a lens with an *f/stop* of *f*/8. Before the advent of fully automated cameras (“point and shoot”), a photographers would routinely select an aperture size for a given camera lens—(thereby setting the *f/stop*), a shutter speed, and a proper focus to achieve both the desired image brightness and sharpness.

Table 3-2 lists the usual choices of *f/stops* (*f*-numbers) available on cameras and the corresponding image irradiance or “brightness”—in watts per square meter. The listing gives the irradiance  $E_0$  as the value for an *f/stop* of 1 and shows how the image irradiance decreases as the lens is “stopped down,” that is, as the adjustable aperture size behind the camera lens is made smaller. From Equation 3-8, it should be clear that, for a given camera lens of focal length *f*, the *f/stop* or *f*-number increases as *D* decreases, that is, as the aperture size decreases. Clearly then, increasing the *f*-number of a lens decreases its light-gathering power.

**Table 3-2. Relative Image Irradiance (Brightness) as a Function of *f/stop* Setting**

<i>f/stop</i> or <i>f</i> -number	Relative Image Irradiance in watts/m <sup>2</sup>
1	$E_0$
1.4	$E_0/2$
2	$E_0/4$
2.8	$E_0/8$
4	$E_0/16$
5.6	$E_0/32$
8	$E_0/64$
11	$E_0/128$
16	$E_0/256$
22	$E_0/512$

Since the *total exposure* in joules/m<sup>2</sup> on the film is the product of the irradiance in joules/(m<sup>2</sup>-s) and the exposure time (shutter speed) in seconds, a desirable film exposure can be obtained in a variety of ways. Accordingly, if a particular film—whose speed is described by an ASA number—is perfectly exposed by light from a particular scene with a shutter speed of 1/50 second and an *f/stop* of *f*/8 (irradiance equals  $E_0/64$  from Table 3-2), it will also be perfectly exposed by any other combination that gives the same total exposure. For example, by choosing

a shutter speed of 1/100 second and an  $f$ /stop of  $f/5.6$ , the exposure time is cut in half while the irradiance ( $E_0/32$ ) is doubled, thereby leaving *no net change* in the film exposure ( $J/m^2$ ).

The *numerical aperture* is another important design parameter for a lens, related directly to how much light the lens gathers. If the focal length of a design lens increases and its diameter decreases, the solid angle (cone) of useful light rays from object to image for such a lens decreases. For example, the concept of a numerical aperture finds immediate application in the design of the objective lens (the lens next to the specimen under observation) for a *microscope*, as we show below. Light-gathering capability is crucial for microscopes.

Figure 3-24 depicts the light-gathering power of a lens relative to a point  $O$  on a specimen covered by a glass slide. Lens  $L$  is the objective lens of a microscope focused on the specimen. On the right side of the symmetry axis of the lens, the light-gathering power of the lens—with *air between the cover slide and the lens*—is depicted in terms of half-angle  $\alpha_{air}$ . On the left side, by contrast, the increased light-gathering power of the lens—with *oil situated between the cover slide and the lens*—is shown in terms of the *larger* half-angle  $\alpha_{oil}$ . The oil is chosen so as to

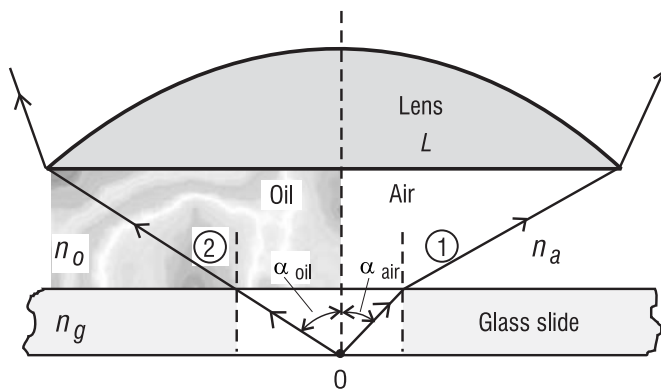

**Figure 3-24** Light-gathering power of oil-immersion and air-immersion lens, showing that  $\alpha_{oil}$  is greater than  $\alpha_{air}$

have an index of refraction ( $n_o$ ) very near that of the cover slide ( $n_g$ ) so that little or no refraction occurs for limiting ray 2 at the glass-oil interface. Consequently the half-angle  $\alpha_{oil}$  is greater than the half-angle  $\alpha_{air}$ . As Figure 3-24 shows, ray 1 suffers refraction at the glass-air interface, thereby restricting the cone of rays accepted by the lens to the smaller half-angle  $\alpha_{air}$ .

The *numerical aperture* of a lens is defined so as to exhibit the difference in solid angles (cones) of light accepted, for example, by an “oil-immersion” arrangement versus an air-immersion setup.

The definition of numerical aperture ( $N.A.$ ) is given in Equation 3-9 as

$$N.A. = n \sin \alpha \quad (3-9)$$

where  $n$  is the index of refraction of the intervening medium between object and lens and  $\alpha$  is the half-angle defined by the limiting ray ( $\alpha_{air}$  or  $\alpha_{oil}$  in Figure 3-24). The “light-gathering” power of the microscope’s objective lens is thus increased by increasing the refractive index of the intervening medium.

In addition, the numerical aperture is closely related to the acceptance angle discussed in Example 3 for both graded-index and step-index optical fibers, as will be shown in Module 1-7, *Optical Waveguides and Fibers*. Since the rays entering the fiber face are in air, the numerical aperture  $N.A.$  is equal simply to  $N.A. = \sin \alpha$ .

It is shown in most basic books on optics (see references listed at end of this module) that image brightness is dependent on values of the  $f$ -number or numerical aperture, in accordance with the following proportionalities:

$$\text{image brightness} \propto \frac{1}{(f\text{-number})^2}$$

$$\text{image brightness} \propto (N.A.)^2$$

In summary, one can *increase* the light-gathering power of a lens and the brightness of the image formed by a lens by *decreasing* the  $f$ -number of the lens (increasing lens diameter) or by *increasing* the numerical aperture of the lens (increasing the refraction index and thus making possible a larger acceptance angle).

### C. Image location by ray tracing

To locate the image of an object formed by a thin lens, we make use of three key points for the lens and associate each of them with a defining ray. The three points are the left focal point  $F$ , the right focal point  $F'$ , and the lens vertex (center)  $V$ . In Figure 3-25 the three rays are shown locating an image point  $P'$  corresponding to a given object point  $P$ , for both a positive and a negative lens. The object is labeled  $OP$  and the corresponding image  $IP'$ . The defining rays are labeled to show clearly their connection to the points  $F$ ,  $F'$ , and  $V$ . In practice, of course, only two of the three rays are needed to locate the desired image point. Note also that the location of image point  $P'$  is generally sufficient to sketch in the rest of the image  $IP'$ , to correspond with the given object  $OP$ .

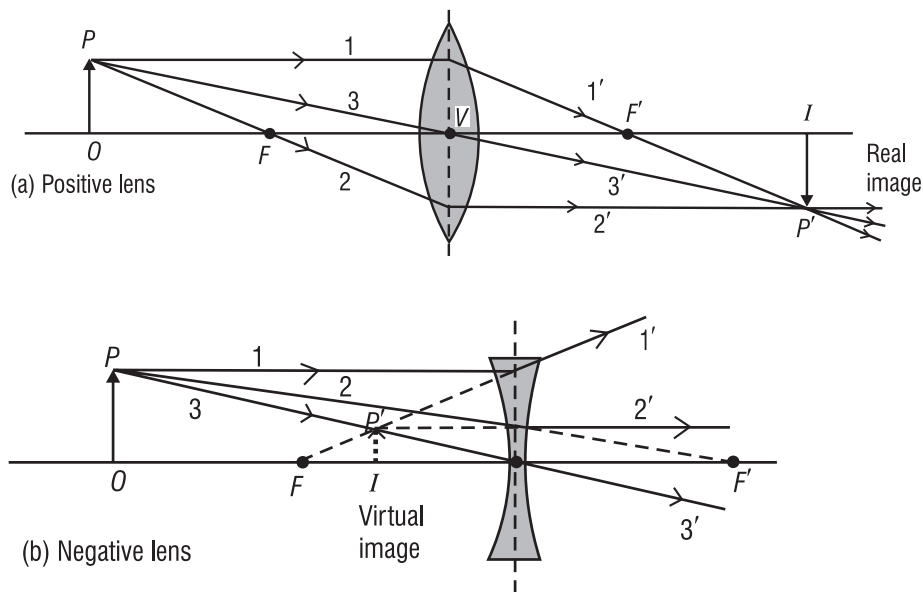
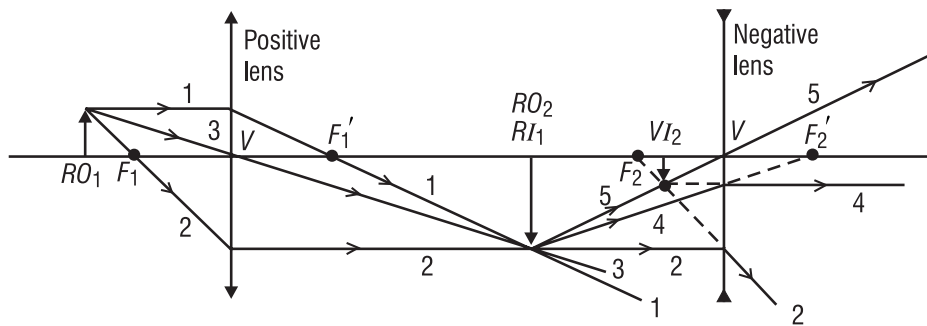

**Figure 3-25** Ray diagrams for image formation by positive and negative lenses

The behavior of rays 1 and 2—connected with the left and right focal points for both the positive and negative lenses—should be apparent from another look at Figure 3-23. The behavior of ray 3—going straight through the lens at its center  $V$ —is a consequence of assuming that the lens has zero thickness. Note, in fact, that, for both Figures 3-23 and 3-25, all the bending is assumed to take place at the dashed vertical line that splits the drawn lenses in half. Also, it should be clear in Figure 3-25 that the positive lens forms a real image while the negative lens forms a virtual image.

One can apply the principles of ray tracing illustrated in Figure 3-25 to a train of thin lenses. Figure 3-26 shows a ray trace through an “optical system” made up of a positive and a negative lens. For accuracy in drawing, a common practice used here is to show the positive lens as a vertical line with normal arrowheads and the negative lens as a vertical line with inverted arrowheads, and to show all ray bending at these lines. Note that the primary object is labeled  $RO_1$  (real object 1) and its image formed by the positive lens is labeled  $RI_1$  (real image 1). The image  $RI_1$  then serves as a real object ( $RO_2$ ) for the negative lens, leading finally to a virtual image  $VI_2$ .

Test your understanding of ray tracing through thin lenses by accounting for each numbered ray drawn in the figure. What happens to rays 1 and 3 relative to the negative lens? Why are rays 4 and 5 introduced? Is this a “fair” practice?



**Figure 3-26** Ray diagram for image formation through two lenses

## D. Lens formulas for thin lenses

As with mirrors, convenient formulas can be used to locate the image mathematically. The derivation of such formulas—as was carried out for spherical mirrors in the previous section—can be found in most texts on geometrical optics. The derivation essentially traces an arbitrary ray *geometrically* and *mathematically* from an object point through the two surfaces of a thin lens to the corresponding image point. *Snell's law* is applied for the ray at each spherical refracting surface. The details of the derivation involve the geometry of triangles and the approximations mentioned earlier— $\sin \phi \cong \phi$ ,  $\tan \phi \cong \phi$ , and  $\cos \phi \cong 1$ —to simplify the final results. Figure 3-27 shows the essential elements that show up in the final equations, relating object distance  $p$  to image distance  $q$ , for a lens of focal length  $f$  with radii of curvature  $r_1$  and  $r_2$  and refractive index  $n_g$ . For generality, the lens is shown situated in an arbitrary medium of refractive index  $n$ . If the medium is air, then, of course,  $n = 1$ .



## BASIC GEOMETRICAL OPTICS

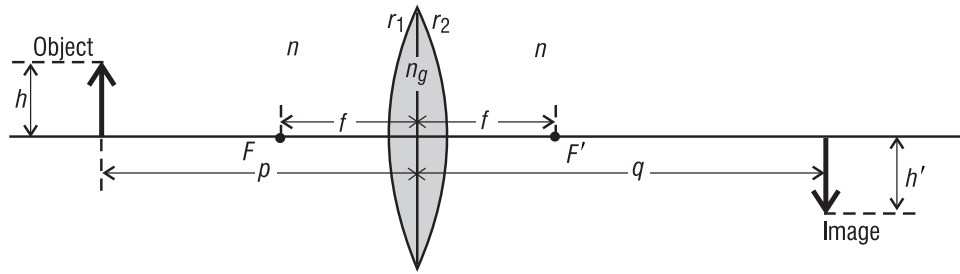

**Figure 3-27** Defining quantities for image formation with a thin lens

**1. Equations for thin lens calculations.** The *thin lens equation* is given by Equation 3-10.

$$\boxed{\frac{1}{p} + \frac{1}{q} = \frac{1}{f}} \quad (3-10)$$

where  $p$  is the object distance (from object to lens vertex  $V$ )

$q$  is the image distance (from image to lens vertex  $V$ )

and  $f$  is the focal length (from either focal point  $F$  or  $F'$  to the lens vertex  $V$ )

For a lens of refractive index  $n_g$  situated in a medium of refractive index  $n$ , the relationship between the parameters  $n$ ,  $n_g$ ,  $r_1$ ,  $r_2$  and the focal length  $f$  is given by the *lensmaker's equation* in Equation 3-11.

$$\boxed{\frac{1}{f} = \left( \frac{n_g - n}{n} \right) \left( \frac{1}{r_1} - \frac{1}{r_2} \right)} \quad (3-11)$$

where  $n$  is the index of refraction of the surrounding medium

$n_g$  is the index of refraction of the lens materials

$r_1$  is the radius of curvature of the front face of the lens

$r_2$  is the radius of curvature of the rear face of the lens

The magnification  $m$  produced by a thin lens is given in Equation 3-12.

$$\boxed{m = \frac{h_i}{h_o} = -\frac{q}{p}} \quad (3-12)$$

where  $m$  is the magnification (ratio of image size to object size)

$h_i$  is the transverse size of the image

$h_o$  is the transverse size of the object

$p$  and  $q$  are object and image distance respectively

**2. Sign convention for thin lens formulas.** Just as for mirrors, we must agree on a sign convention to be used in the application of Equations 3-10, 3-11, and 3-12. It is:

- Light travels initially from left to right toward the lens.

- Object distance  $p$  is *positive* for *real* objects located to the *left* of the lens and *negative* for *virtual* objects located to the *right* of the lens.
- Image distance  $q$  is *positive* for *real* images formed to the *right* of the lens and *negative* for *virtual* images formed to the *left* of the lens.
- The focal length  $f$  is *positive* for a *converging* lens, *negative* for a *diverging* lens.
- The radius of curvature  $r$  is *positive* for a *convex* surface, *negative* for a *concave* surface.
- Transverse distances ( $h_o$  and  $h_i$ ) are *positive* *above* the optical axis, *negative* *below*.

Now let's apply Equations 3-10, 3-11, and 3-12 in several examples, where the use of the sign convention is illustrated and where the size, orientation, and location of a final image are determined.

---

### Example 8

A double-convex thin lens such as that shown in Figure 3-21 can be used as a simple “magnifier.” It has a front surface with a radius of curvature of 20 cm and a rear surface with a radius of curvature of 15 cm. The lens material has a refractive index of 1.52. Answer the following questions to learn more about this simple magnifying lens.

- What is its focal length in air?
- What is its focal length in water ( $n = 1.33$ )?
- Does it matter which lens face is turned toward the light?
- How far would you hold an index card from this lens to form a sharp image of the sun on the card?

#### Solution:

- Use the lensmaker's equation. With the sign convention given, we have  $n_g = 1.52$ ,  $n = 1.00$ ,  $r_1 = +20$  cm, and  $r_2 = -15$  cm. Then

$$\frac{1}{f} = \left( \frac{n_g - n}{n} \right) \left( \frac{1}{r_1} - \frac{1}{r_2} \right) = \left( \frac{1.52 - 1}{1} \right) \left( \frac{1}{20} - \frac{1}{-15} \right) = 0.0607$$

So  $f = +16.5$  cm (a converging lens, so the sign is positive, as it should be)

- $\frac{1}{f} = \left( \frac{1.52 - 1.33}{1.33} \right) \left( \frac{1}{20} - \frac{1}{-15} \right) = 0.0167$

$f = 60$  cm (converging but less so than in air)

- No, the magnifying lens behaves the same, having the same focal length, no matter which surface faces the light. You can prove this by reversing the lens and repeating the calculation with Equation 3-11. Results are the same. But **note carefully**, reversing a *thick* lens changes its effect on the light passing through it. The two orientations are *not* equivalent.

(d) Since the sun is very far away, its light is collimated (parallel rays) as it strikes the lens and will come to a focus at the lens focal point. Thus, one should hold the lens about 16.5 cm from the index card to form a sharp image on the card.

Example 9

A two-lens system is made up of a converging lens followed by a diverging lens, each of focal length 15 cm. The system is used to form an image of a short nail, 1.5 cm high, standing erect, 25 cm from the first lens. The two lenses are separated by a distance of 60 cm. See accompanying diagram. (Refer to Figure 3-26 for a ray-trace diagram of what's going on in this problem.)

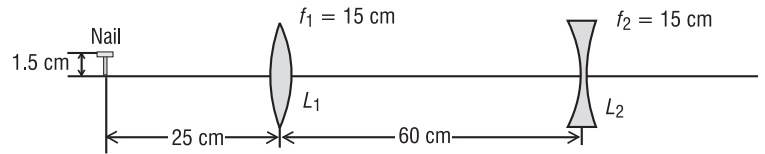

Locate the final image, determine its size, and state whether it is real or virtual, erect or inverted.

**Solution:** We apply the thin lens equations to each lens in turn, making use of the correct sign convention at each step.

$$\text{Lens } L_1: \quad \frac{1}{p_1} + \frac{1}{q_1} = \frac{1}{f_1} \quad \text{or} \quad \frac{1}{25} + \frac{1}{q_1} = \frac{1}{15} \quad (f_1 \text{ is } + \text{ since lens } L_1 \text{ is converging.})$$

$q_1 = +37.5$  cm (Since the sign is positive, the image is real and located 37.5 cm to the right of lens  $L_1$ .)

$$\text{Lens } L_2: \quad \frac{1}{p_2} + \frac{1}{q_2} = \frac{1}{f_2} \quad \text{where } p_2 = (60 - 37.5) = 22.5 \text{ cm}$$

Since the first image, a distance  $q_1$  from  $L_1$ , serves as the object for the lens  $L_2$ , this object is to the left of lens  $L_2$ , and thus its distance  $p_2$  is positive. The focal length for  $L_2$  is negative since it is a diverging lens. So, the thin lens equation becomes

$$\frac{1}{22.5} + \frac{1}{q_2} = \frac{1}{-15}, \quad \text{giving } q_2 = -9 \text{ cm}$$

Since  $q_2$  is negative, it locates a *virtual* image, 9 cm to the left of lens  $L_2$ . (See Figure 3-26.)

The overall magnification for the two-lens system is given by the combined magnification of the lenses. Then

$$m_{\text{sys}} = m_1 \times m_2 = \left( -\frac{q_1}{p_1} \right) \left( -\frac{q_2}{p_2} \right) = \left( -\frac{37.5}{25} \right) \left( -\frac{-9}{22.5} \right) = -0.6$$

Thus, the final image is inverted (since overall magnification is negative) and is of final size  $(0.6 \times 1.5 \text{ cm}) = 0.9 \text{ cm}$ .

---

# Laboratory

---

In this laboratory you will perform the following simple experiments with prisms and lenses:

- Determine the index of refraction of a prism material.
- Demonstrate total internal reflection (TIR) with right-angle prisms and show how to use the prisms to produce (a) 90° bending, (b) retroreflection, and (c) “periscope-type” bending.
- Determine the index of refraction of a thin-lens material.
- Determine the focal lengths of convex and concave lenses.

## Equipment List

The following equipment is needed to complete this laboratory:

- 1 equilateral prism<sup>a</sup> (25-mm faces by 25 mm long works well)
- 2 45°-45°-90° prisms<sup>a</sup> (25-mm legs, 35-mm hypotenuse, 25 mm thick)
- 2 diode laser pointers<sup>b</sup> (5 mW or less)
- 1 spherometer<sup>b</sup>
- 1 double-convex lens<sup>a</sup> (75-mm diameter by 150-mm focal length)
- 1 double-concave lens<sup>a</sup> (75-mm diameter by 150-mm focal length)
- 1 protractor
- 1 white cardboard screen
- Index cards, white paper sheet, ( 8½" × 11" and 11" × 17"), masking tape, and ruler

## Procedure

### **A. Index of Refraction of a Prism Material**

1. Arrange the laser pointer, equilateral prism, and white cardboard screen on a flat tabletop as shown in Figure L-1. Center the prism over a sheet of white paper. Fasten down the white paper, cardboard screen, and laser with tape.

---

<sup>a</sup> These items are readily available from Edmund Scientific, Barrington, New Jersey, 609-573-6250, as parts of their “Educational Quality Demonstration Optics,” at reasonable prices. See their Industrial Optics Division catalog.

<sup>b</sup> These items are also available from Edmund Scientific but are more expensive.

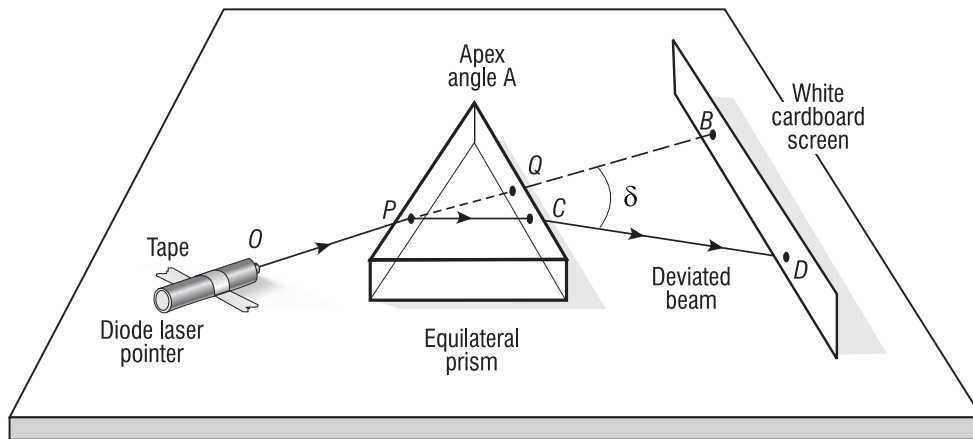

**Figure L-1** Setup for measuring minimum angle of deviation

- As you rotate the prism relative to the incident laser beam, the laser spot  $D$  on the screen moves, so the angle of deviation  $\delta$  will become larger or smaller. By experimentation, determine the *smallest angle of deviation* ( $\delta_m$ ) between an original beam direction  $OPQB$  and the deviated beam  $CD$ . (It should be clear that the farther the screen is from the prism the more precise will be your determination of  $\delta_m$ , since small changes in spot  $D$  will then be more exaggerated.)
- When you have achieved the minimum angle for  $\delta$ , carefully tape the prism in place. Trace the prism edges on the paper, the straight segments  $OP$  and  $QB$  along the *original direction*, and the segment  $CD$ . (**Note:** Location of laser spots  $Q$ ,  $C$  on the exit face of the prism and  $B$ ,  $D$  on the screen are needed to be able to draw segments  $QB$  and  $CD$ .) With the line segments drawn, remove the prism and measure the minimum angle  $\delta_m$  with a protractor. Complete a ray trace of the incident beam through the prism, deviated at angle  $\delta_m$ . Is the segment  $DC$  parallel to the prism base? Should it be?
- Record the measured angle  $\delta_m$  and the apex angle  $A$ . Use the formula

$$n = \frac{\sin\left(\frac{A + \delta_m}{2}\right)}{\sin\frac{A}{2}}$$

to calculate the index of refraction  $n$ . Compare your value with values given in Table 3-1. Does it agree with any value given there? What is your best guess for the prism material?

### B. Total Internal Reflection (TIR)

(When you have finished this part, you will have three different traces of laser light interacting with right-angle prisms, all on an 11" × 17" sheet of white tracing paper.)

- Set a right-angle prism on one of its parallel sides on a sheet of 11" × 17" white tracing paper. Tape the paper and prism in position. Shine a diode laser beam onto an appropriate face of the prism so that it *undergoes total internal reflection* (TIR) and exits the prism at 90° to its original direction of entry. Use index cards as a screen to “locate” the laser beam

outside the prism. On the paper, trace the edges of the prism, a line along the incident beam, a line along the path through the prism, and a line along the exit beam. Label the angles of incidence and reflection and their values at the face where TIR takes place. What would you need to know to determine the critical angle at this face? Is the incident angle on the face where TIR occurs larger or smaller than the critical angle?

2. Move the right-angle prism to a different position on the 11" × 17" paper and tape it down. Direct the diode laser beam onto an appropriate face so that the beam returns along a direction parallel to its entering direction. Use index cards to "locate" the beam path. When you have achieved this condition of *retroreflection*, trace the edges of the prism, the entering beam, the path through the prism, and the exit beam. Draw appropriate angles at the faces where TIR occurs and give their correct values.
3. Move two right-angle prisms to a new location on the 11" × 17" paper. Arrange them to produce "periscope action." This action requires, for example, that a horizontal beam that enters at one level be deflected downward 90° and exit horizontally at a different level, as shown in the accompanying sketch. Here the dashed squares indicate the locations of the two prisms. Use index cards to locate the beam through the prism arrangement.

When you have achieved the "periscope" geometry, tape the prisms down. Trace their edges, and trace the laser beam path from initial entry to final exit. Show where TIR occurs and label the incident and reflected angles there correctly, at each position.

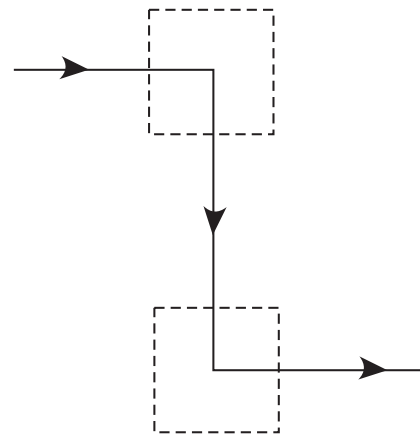

### C. Index of Refraction of a Thin Lens

Use the lensmaker's equation  $\left[ \frac{1}{f} = \left( \frac{n_g - n}{n} \right) \left( \frac{1}{r_1} - \frac{1}{r_2} \right) \right]$  to determine the value of  $n_g$  for the

double-convex lens. Use a ruler, overhead lights, and an index card to obtain a good approximation for the focal length of the lens. (Going outside and imaging the sun would be even better.) Use a spherometer to measure the radii of curvature  $r_1$  and  $r_2$ . (You will have to be especially creative to get  $r_1$  and  $r_2$  if you don't have access to a spherometer.) With the values of  $f$ ,  $r_1$ , and  $r_2$ , solve the lensmaker's equation for  $n_g$ , the index of refraction of the lens glass. Compare your value with values given in Table 3-1. Do you have a match?

### D. Measuring the Focal Lengths of Thin Lenses

Set up the two diode lasers on a stand or optical bench so that they emit beams parallel to one another and normal to the plane defining the vertical position of the thin lens. See Figure L-2. (To see the beams converging on the image side of the lens, you will have to use chalk-dust particles or smoke—some form of cloud—to illuminate the path.) By moving the screen forward and backward, you can locate a position where the beams cross to form the "smallest" spot. This is the *focal point* for the lens. Measuring the optical bench distance from lens to focal

## BASIC GEOMETRICAL OPTICS

point gives the *focal length*. Compare this value to the value you obtained in part C, when you simply imaged a “distant” object on an index card. Which method is more accurate? Which method is easier?

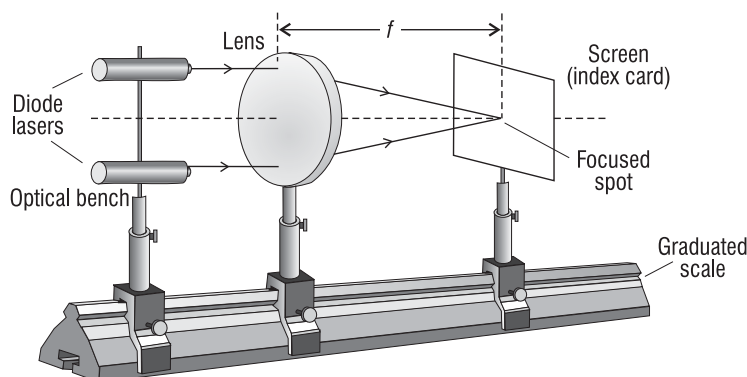

**Figure L-2** Setup for determining focal length of a positive lens

Replace the positive lens in Figure L-2 with the negative lens. The challenge now is greater since the two laser beams diverge on the right side of the lens—and do not form a real image anywhere. Can you design a method to locate the spots of the two parallel beams at the lens and the spots for the two diverging beams on the right of the lens, then “trace” your way back to locate the focal point on the left side of the lens? If you can locate the focal point on the left, you can then measure its distance from the lens to get the focal length of the negative lens.

---

## Student Project (optional)

Design a 10X beam expander using first a combination of two positive lenses and next a combination of a positive and a negative lens. Carefully draw each design to scale. Refer to publications such as the *Melles-Griot Catalog* or the *Edmund Scientific Industrial Optics Catalog* to obtain lens diameters, focal lengths, and approximate costs for each beam-expander design (less housing). Test each design on an optical bench and measure the size of the incident and exit beams. Determine how closely each beam expander meets the 10X specification. Is there any reason for choosing one design over the other?

## Other Resources

- The Education Council of the Optical Society of America (OSA) has prepared a *discovery kit* designed to introduce students to modern optical science and engineering. The kit includes two thin lenses, a Fresnel lens, a mirror, a hologram, an optical illusion slide, a diffraction grating, one meter of optical fiber, two polarizers, four color filters, and instructions for eleven detailed experiments. OSA offers teacher membership opportunities. Contact the Optical Society of America, 2010 Massachusetts Avenue, NW, Washington, D.C. 20036, 800-762-6960.
- K-12 Optics Outreach kit, available from SPIE, Bellingham, Washington.

- Atneosen, R., and R. Feinberg. "Learning Optics with Optical Design Software," *American Journal of Physics*, Vol 59, March 1991: pp 242-47.
- "Teaching Optics with an O/H Projector," Douglas S. Goodman, Polaroid Corporation, 38 Henry St., Cambridge, Maryland.

## References

### *Textbooks*

- Beiser, Arthur. *Physics*, 3rd Edition, Menlo Park, California: The Benjamin/Cummings Publishing Company, 1982.
- Hecht, E., and A. Zajac. *Optics*, 2nd Edition. Reading, Massachusetts: Addison Wesley Publishing Company, 1987.
- Pedrotti, F., and L. Pedrotti. *Introduction to Optics*, 2nd Edition. Englewood Cliffs, New Jersey: Prentice Hall, Inc., 1993.
- Pedrotti, F., and L. Pedrotti. *Optics and Vision*. Englewood Cliffs, New Jersey: Prentice Hall, Inc., 1998.
- Serway, R. A. *Principles of Physics*. Orlando, Florida: Saunders College Publishing, 1992.
- Waldman, Gary. *Introduction to Light*. Englewood Cliffs, New Jersey: Prentice Hall, Inc., 1983.

### *Articles*

- Englert, B-G., M. O. Scully, and H. Walther. "The Duality in Matter and Light," *Scientific American* (December 1994), 86.
- Weisskopf, Victor F. "How Light Interacts with Matter," *Lasers and Light*, Readings from *Scientific American*. W. H. Freeman and Company, 1969, pp 14-26.

### *Optical Manufacturing Companies*

- Optics and Optical Instruments Catalog*. Edmund Scientific, Industrial Optics Division, Barrington, New Jersey.
- Melles-Griot Catalog*. Melles-Griot Optical Systems, Rochester, New York, and Melles-Griot Photonics Components, Irvine, California.



## Problem Exercises

- Use the *law of reflection* to determine the (a) minimum height and (b) position for a plane mirror that just allows a 5'6" woman standing on the floor in front of the mirror to see both her head and feet in the mirror. See sketch.

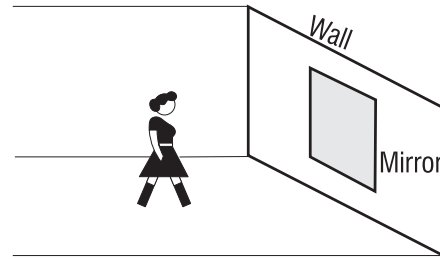

- White light contains all wavelengths from deep blue at 400 nm to deep red at 700 nm. A narrow beam of collimated white light is sent through a prism of apex angle  $20^\circ$  as shown. The prism is made of light flint glass whose refractive index at 400 nm is 1.60 and at 700 nm is 1.565. What is the angular spread between the red and blue light at the minimum angle of deviation for each?

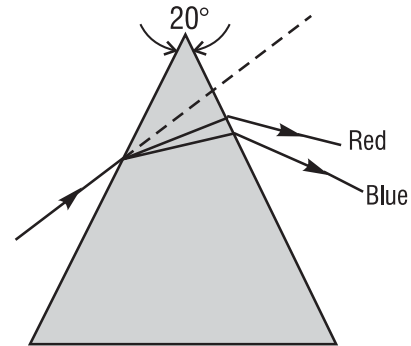

- A ray of sodium light at 589 nm is incident on a rectangular slab of crown glass at an angle of  $45^\circ$  with the normal. (a) At what angle to the normal does this ray exit the slab? (b) What is the direction of the exiting ray relative to the entering ray? (c) Sketch an accurate trace of the ray through the slab.

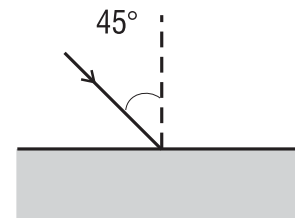

- An object 3 cm high is placed 20 cm to the left of (a) a convex and (b) a concave spherical mirror, each of focal length 10 cm. Determine the position and nature of the image for each mirror.
- Make a ray-trace diagram—on an  $8\frac{1}{2}'' \times 11''$  sheet of white paper—that locates the image of a 2-cm object placed 10 cm in front of a concave spherical mirror of curvature 6 cm. Make your drawing *to scale*. Where is the image located and what are its orientation and its size? Repeat this for a convex spherical mirror of the same curvature.

- A fish in a lake looks up at the surface of the water. At what distance  $d$  along the surface, measured from the normal, is a water-skimming insect safe from the roving eye of the fish?

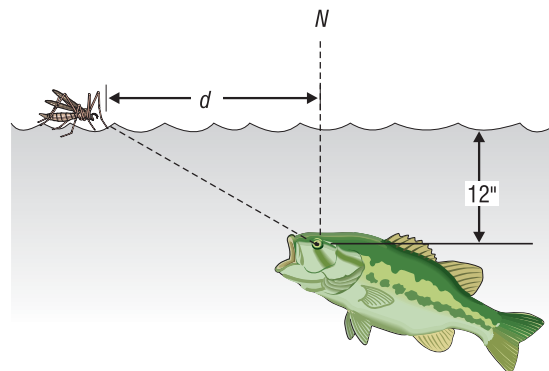

7. What is the light cone acceptance angle for an optical fiber of diameter  $100\ \mu$ , located in air, having a plastic core of index 1.49 and a plastic cladding of index 1.39? Make a sketch of the fiber, showing a limiting ray along the surface of the acceptance cone entering the fiber and refracting appropriately.

8. A laser beam is incident on the end face of a cylindrical rod of material as shown in the sketch. The refractive index of the rod is 1.49. How many internal reflections does the laser beam experience before it exits the rod?

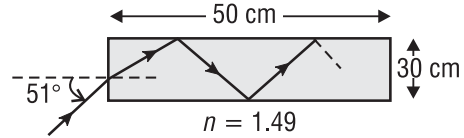

9. A thin, double-convex lens has a refractive index of 1.50. The radius of curvature of the front surface is 15 cm and that of the rear surface is 10 cm. See sketch. (a) How far from the lens would an image of the sun be formed? (b) How far from the lens would an image of a toy figure 24 cm from the lens be formed? (c) How do the answers to (a) and (b) change if you flip the lens over?

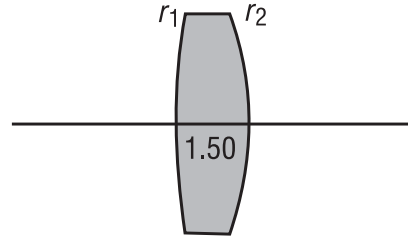

10. The object shown in the accompanying sketch is midway between the lens and the mirror. The radius of curvature of the mirror is 20 cm. The concave lens has a focal length of 16.7 cm. (a) Where is the light that travels first to the mirror and then to the lens finally imaged? (b) Where is the light finally imaged that travels first to the lens? (Note: Be especially careful of applying the sign convention!)

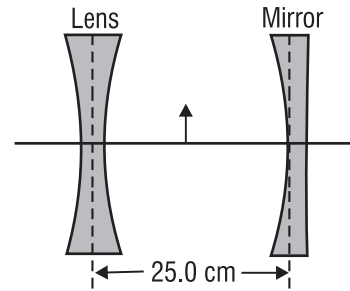

11. A ray of light makes an angle of incidence of  $45^\circ$  at the center of one face of a transparent cube of refractive index 1.414. Trace the ray through the cube, providing backup calculations to support your answer.
12. Two positive thin lenses, each of focal length  $f = 3\text{ cm}$ , are separated by a distance of 12 cm. An object 2 cm high is located 6 cm to the left of the first lens. See sketch.

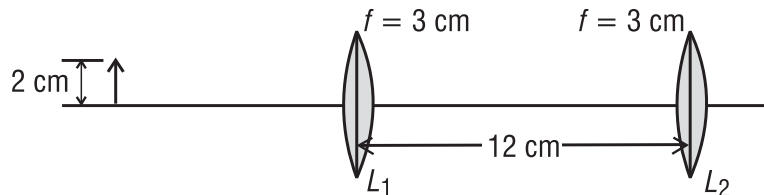

On an  $8\frac{1}{2}'' \times 11''$  sheet of paper, make a drawing of the two-lens system, *to scale*. (a) Use ray-tracing techniques to locate the final image and describe its size and nature. (b) Use the thin-lens equation to locate the position and size of the final image. How well do your results for (a) and (b) agree?

## BASIC GEOMETRICAL OPTICS

13. A plano-convex lens of focal length 25.0 cm is to be made with crown glass of refractive index 1.52. Calculate the radius of curvature of the grinding and polishing tools to be used in making this lens.
14. An eyepiece is made of two positive thin lenses, each of focal length  $f = 20$  mm, separated by a distance of 16 mm. (a) Where must a small object viewed by the eyepiece be placed so that the eye receives parallel light from the eyepiece? (b) Does the eye see an erect image relative to the object? Is it magnified? (c) Use a ray-trace diagram to answer these questions by inspection.

